

180 CFX - ONE WAY SYSTEM ASSEMBLY - HUB

STEP 1

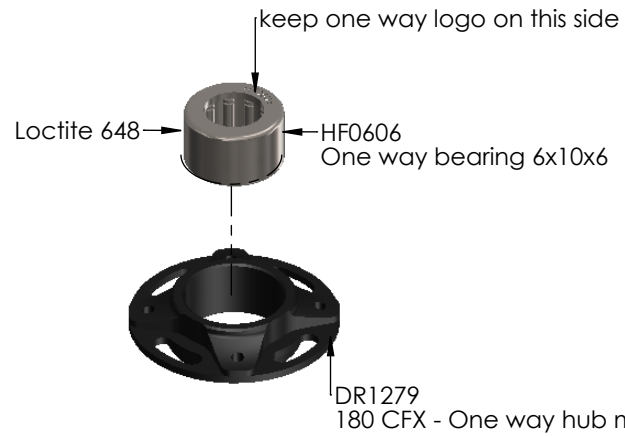

STEP 2

4 x PAN1.6X3
M1.6x3 Pan head screw silver
Loctite 242

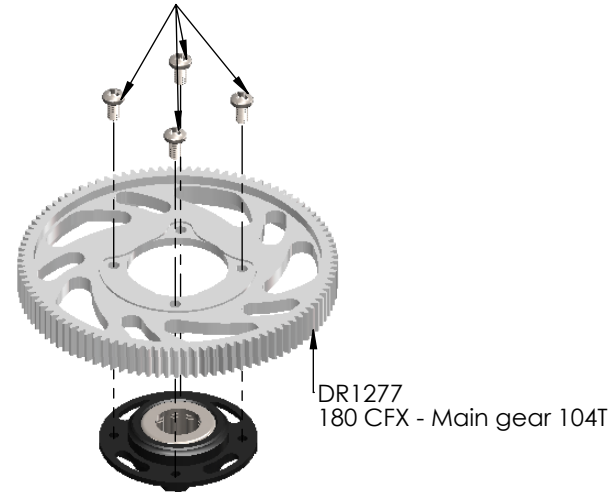

ASSEMBLY VIEW

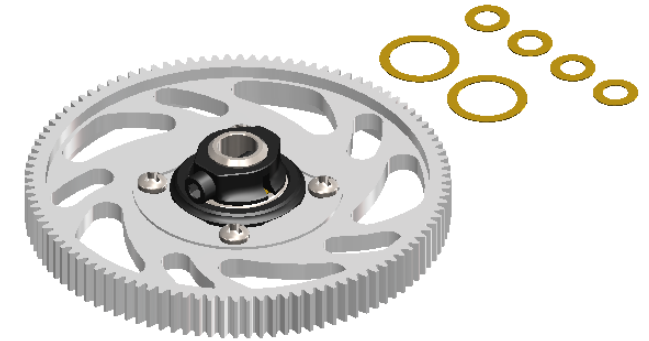

STEP 3

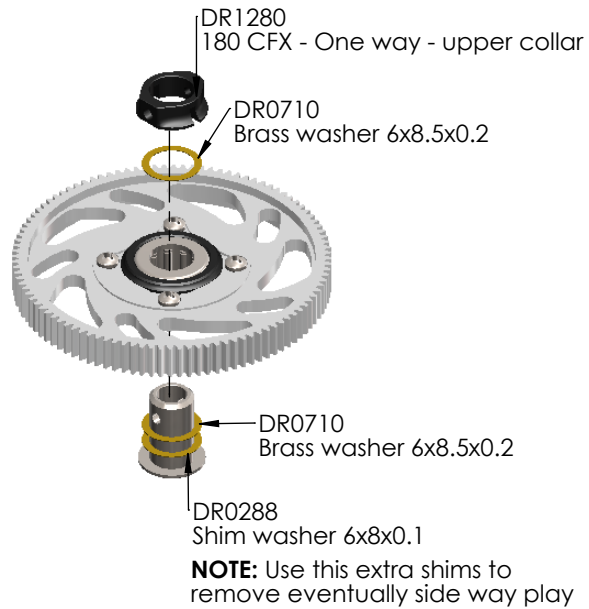

STEP 4

NOTE: Use this extra shims to remove eventually side way play

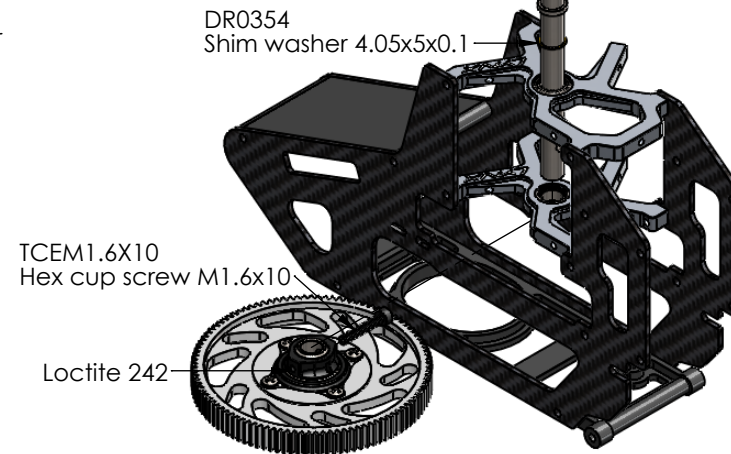

NOTE