

oxy3

Instruction Manual

OXY 3 - Tareq Edition



Tareq Alsaadi

OXY HELI

Visit our website here to update new vision manual: <http://oxyheli.com/>

VERY IMPORTANT NOTE:

- Inside Box 02 you will find the instruction manual in PDF format on cd rom.
- Visit the Oxy Heli web site www.oxyheli.com to download the latest version of the manual.
- In the same box you will also find your serial number card. Please take a moment to visit the Oxy Heli web site and follow the instructions to register your helicopter and serial number.
- It is important you take few minutes to register your helicopter and serial number with us. This is the only way to be in contact with us to receive news, promotional information and technical tips.
- We will also choose five serial numbers each year that will win a discount coupon worth 200USD each to spend at the Oxy Heli or Lynx Heli web sites.
- Thank you for your purchase, and we wish you the best enjoyment with your new Oxy 3 Helicopter.

INDEX

Chapter 1 - Specifications	page 1	Chapter 12 - Flybarless Installation	page 17
Chapter 2 - Important Notes	page 2	Chapter 13 - Transmission Assembly	page 18 - 21
Chapter 3 - Required Tools for Assembly	page 3	Chapter 14 - Belt Tension & Adjustment	page 22
Chapter 4 - What's Inside The Box	page 4	Chapter 15 - Head Assembly	page 23 - 27
Chapter 5 - Tail Assembly	page 5 - 7	Chapter 16 - Servo and FBL System Start Up	page 28
Chapter 6 - Boom Assembly	page 8 - 9	Chapter 17 - Servo Installation	page 29 - 31
Chapter 7 - Carbon Frame	page 10 - 12	Chapter 18 - Servo Rod and Landing Gear Installation	page 32
Chapter 8 - Align and Lock Frame Panel	page 13	Chapter 19 - Flight / Maintenance	page 33
Chapter 9 - Motor Installation	page 14	Chapter 20 - Adjustment Servo with Leveler	page 34 - 35
Chapter 10 - Pinion selection and rpm	page 15	Chapter 21 - Exploded View	page 36 - 39
Chapter 11 - ESC Installation	page 16	Chapter 22 - Spare Part	page 40- 49

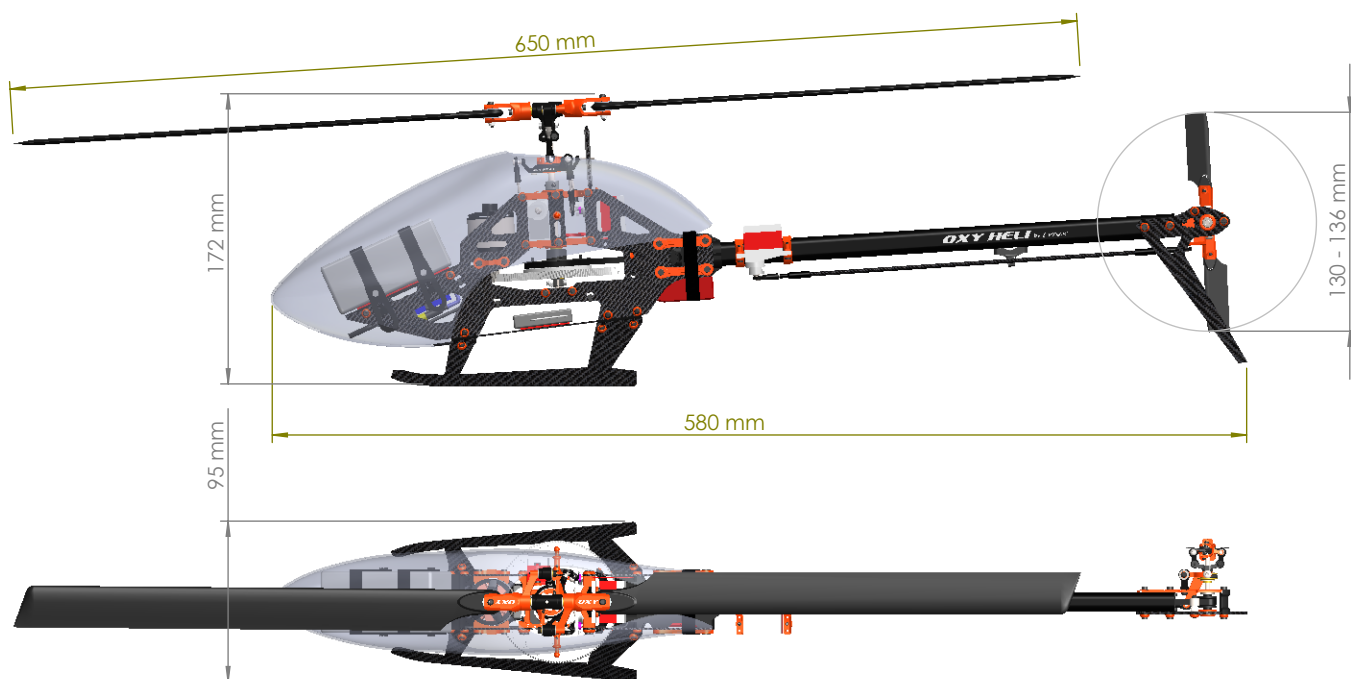
SPECIFICATIONS

-Standard main rotor diameter	: 650mm (with 285mm blades).
-Standard main blade length	: 285mm.
-Main Grip Clamping	: M2 / 5.6 mm root.
-Standard tail rotor diameter	: 130-136mm.
-Standard tail blade length	: 47 - 50mm.
-Tail Blade Clamping	: M2 / 3.5 mm root.
-Weight	: 450g (ready to fly excluding batteries)
-Maximum motor size	: diameter 28mm.
-Maximum battery size	: length 76mm, height 35mm, width 37mm, weight 180gr

IMPORTANT NOTE.

This model helicopter has been designed and produced to be a high performance 3D machine. With its simple design and low parts count, pilots of all skill levels will appreciate its easy reparability. This is not a toy. Please take care assembling the model, and take care and responsibility when you fly it. We take no responsibility for any damage or injuries, either direct or consequential, from the use of this product. If you are not experienced in the assembly and flying of a high performance model helicopter we recommend you seek the assistance of an experienced pilot. Above all, fly safely and we hope you enjoy this model.

SAFETY GUIDELINES.

Only fly this model in areas designated for the use of model aircraft. Ensure you obtain indemnity insurance, normally available through your National model aircraft association. Remain at least 6 meters (20 feet) from the model at all times. Never allow spectators or animals any closer than 30 meters (100 feet) from the model.

NOTES FOR ASSEMBLY.

Please read this instruction manual fully before beginning assembly of this model helicopter. Be sure to use quality tools during the assembly process, and remember not to overtighten small fasteners. Note the following symbols which are used in this manual. Use thread lock sparingly where indicated. If you are unsure about an assembly step, please seek the advice of an experienced pilot. Warranty on any parts is only applicable prior to assembly of the part on the model.

NONE OF THE PRE ASSEMBLED PARTS HAVE THREAD LOCK ON THE SCREWS. IS IMPORTANT TO READ AND FOLLOW THE ASSEMBLY NOTES IN EACH STEP. INCORRECT ASSEMBLY OR NOT USING THREAD LOCK WILL CAUSE A CRASH OR INJURY.



Important note

Use Loctite 243
Medium StrengthUse Loctite 262
High StrengthUse Loctite 648
Bonding

Use CA Glue



Use Silicone Grease

TOOLS REQUIRED

1.5mm Hex Screw Driver
(High quality)

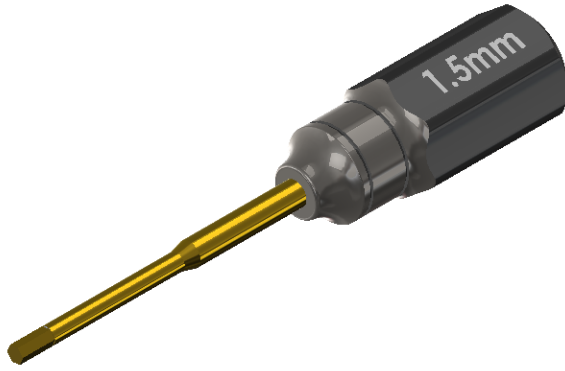

 Two Tool Required

2.5 mm Hex Screw Driver
(High quality)



Small Tip - Flat Screw Driver

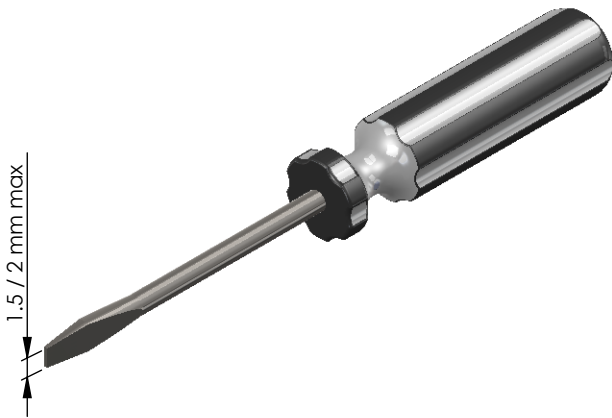

Caliper

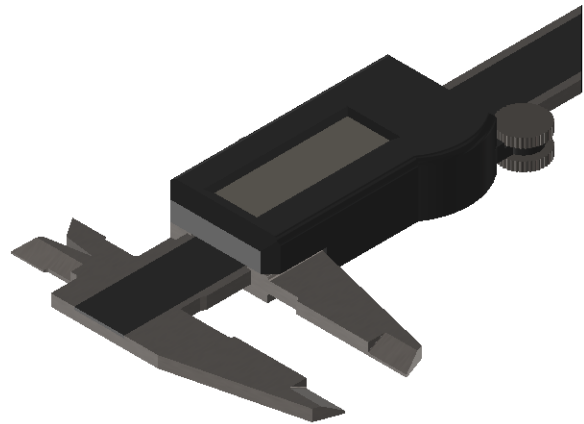

Needle Nose Pliers

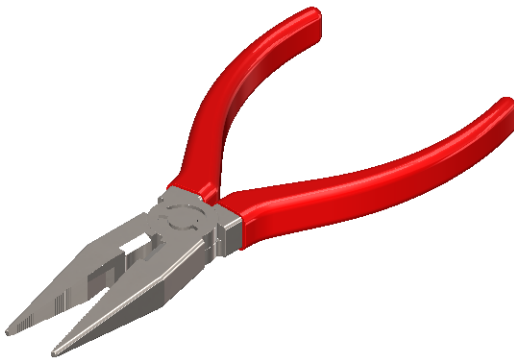

Uniball Pliers

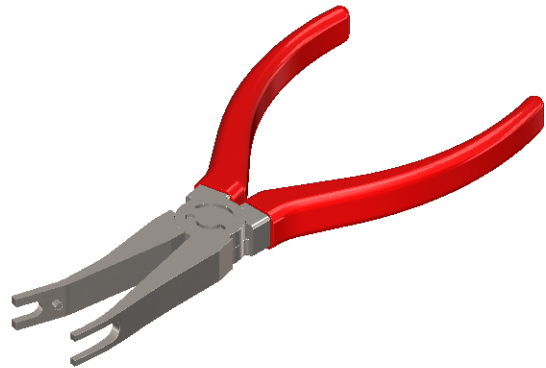

INSIDE THE BOX

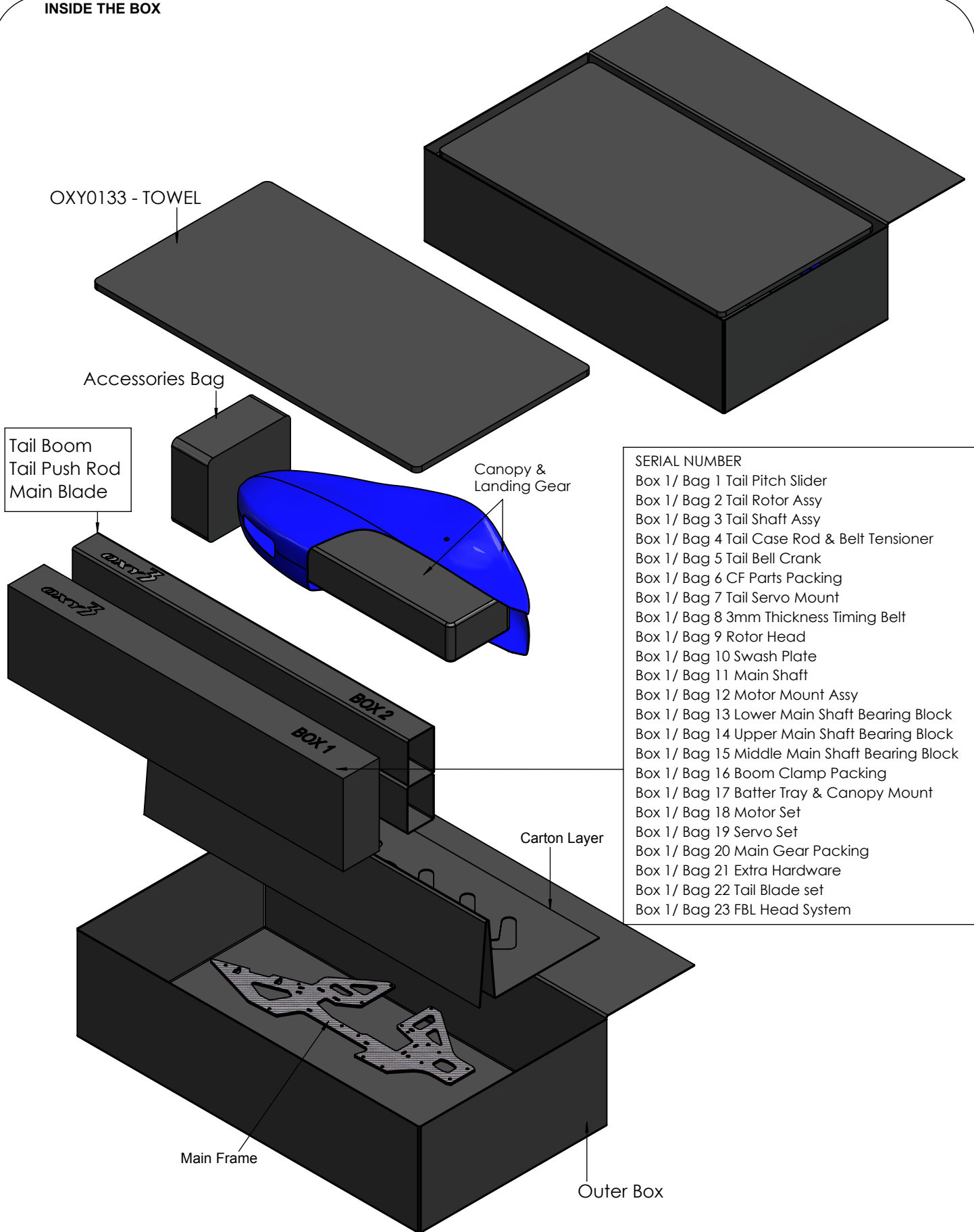

Tail Boom
Tail Push Rod
Main Blade

- SERIAL NUMBER**
- Box 1/ Bag 1 Tail Pitch Slider
 - Box 1/ Bag 2 Tail Rotor Assy
 - Box 1/ Bag 3 Tail Shaft Assy
 - Box 1/ Bag 4 Tail Case Rod & Belt Tensioner
 - Box 1/ Bag 5 Tail Bell Crank
 - Box 1/ Bag 6 CF Parts Packing
 - Box 1/ Bag 7 Tail Servo Mount
 - Box 1/ Bag 8 3mm Thickness Timing Belt
 - Box 1/ Bag 9 Rotor Head
 - Box 1/ Bag 10 Swash Plate
 - Box 1/ Bag 11 Main Shaft
 - Box 1/ Bag 12 Motor Mount Assy
 - Box 1/ Bag 13 Lower Main Shaft Bearing Block
 - Box 1/ Bag 14 Upper Main Shaft Bearing Block
 - Box 1/ Bag 15 Middle Main Shaft Bearing Block
 - Box 1/ Bag 16 Boom Clamp Packing
 - Box 1/ Bag 17 Batter Tray & Canopy Mount
 - Box 1/ Bag 18 Motor Set
 - Box 1/ Bag 19 Servo Set
 - Box 1/ Bag 20 Main Gear Packing
 - Box 1/ Bag 21 Extra Hardware
 - Box 1/ Bag 22 Tail Blade set
 - Box 1/ Bag 23 FBL Head System

ASSEMBLY PARTS FINDER HELP NOTE:
In each assembly step you will see a parts finder note. Follow this information to find the necessary parts inside the Oxy 3 box.

Tail Pitch Slider Assembly. (Box 02 / Bag 1)

Step 1

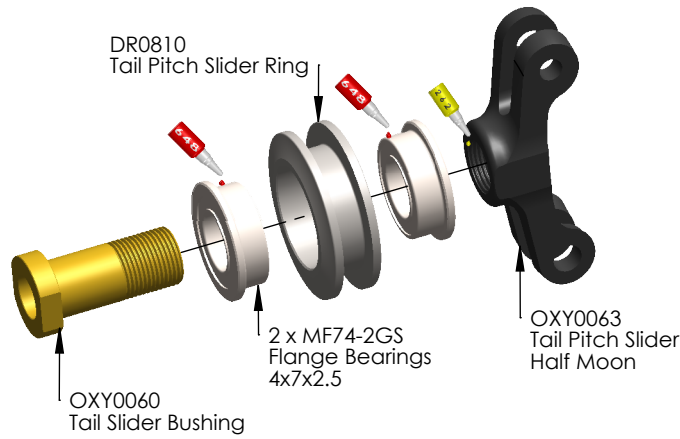

Important Note:
This part, for tuning reasons, comes factory pre assembled with grease and loctite. It is ready to use.

Step 2

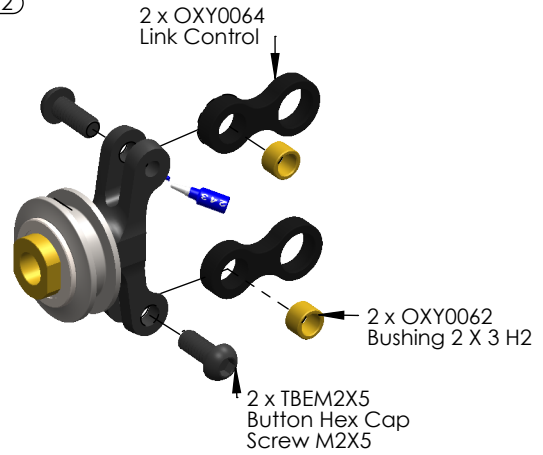

Important Note:
This part comes pre assembled WITHOUT thread lock. Follow the instruction for final assembly.

Important Note:
Ensure thread lock does not contaminate the bushings. In case of friction, clean then reassembly.

Tail Grip Assembly. (CNC components)

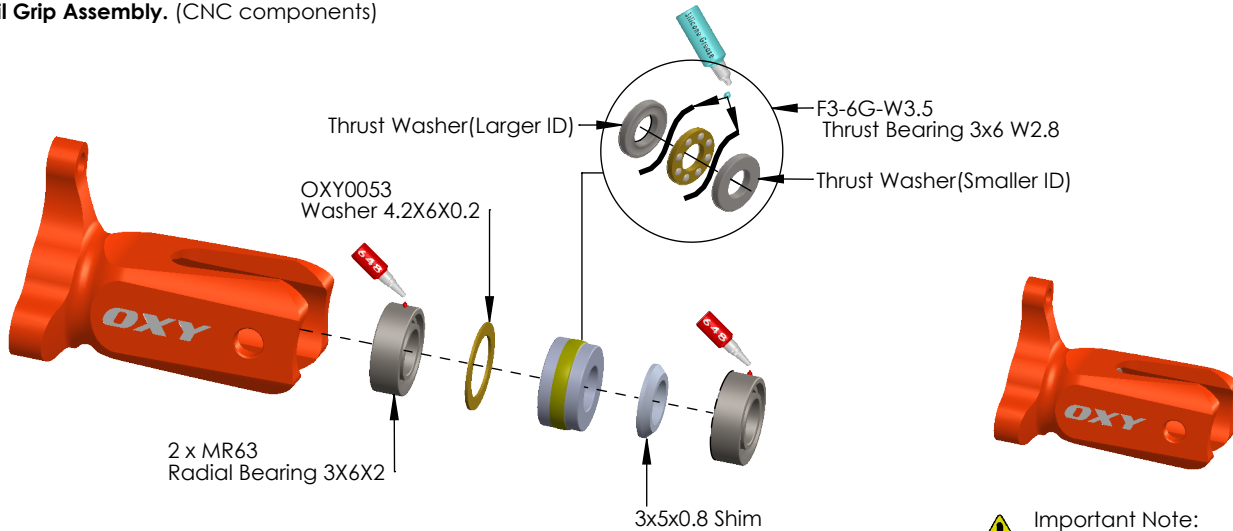

Important Note:
This part, for tuning reasons, comes factory pre assembled with grease and loctite. It is ready to use.

Tail Hub Assembly. (CNC components)

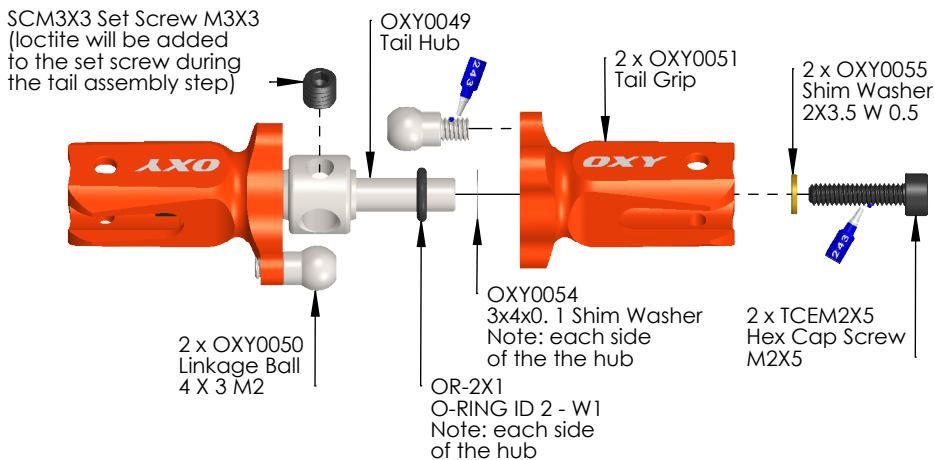

Important Note:
This part comes pre assembled WITHOUT thread lock. Follow the instruction for final assembly.

15T Pulley - Tail Shaft Assembly ready to use. (Box 1/ Bag 3)



Pre Tensioner Belt Pulley Assembly. (Box 1/ Bag 4)

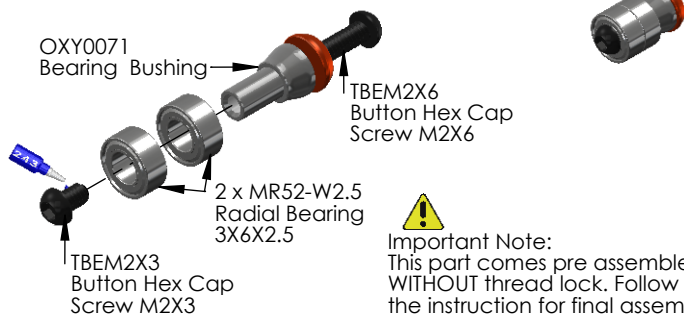

Important Note:
This part comes pre assembled **WITHOUT** thread lock. Follow the instruction for final assembly.

Tail Bell Crank Assembly. (Box 1 / Bag 5)

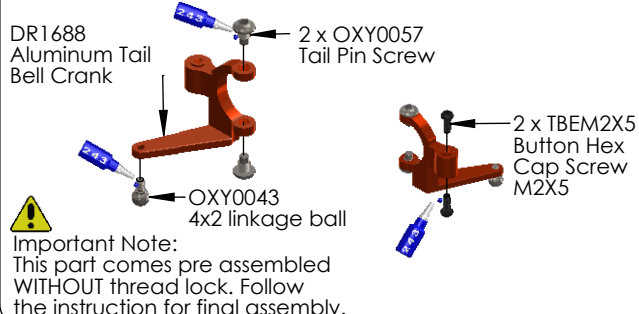

Important Note:
This part comes pre assembled **WITHOUT** thread lock. Follow the instruction for final assembly.

Vertical Fin Assembly. (Box 1/ Bag 6)

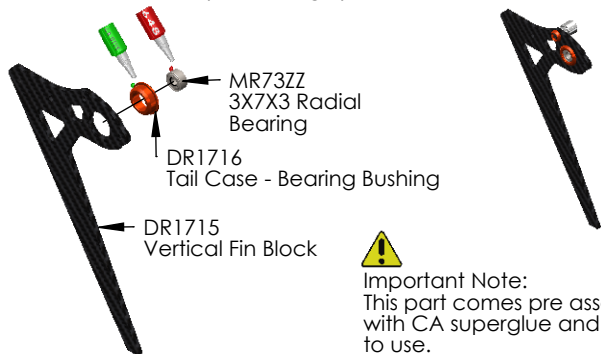

Important Note:
This part comes pre assembled with CA superglue and is ready to use.

Tail Case Plate Assembly. (Box 1/ Bag 6)

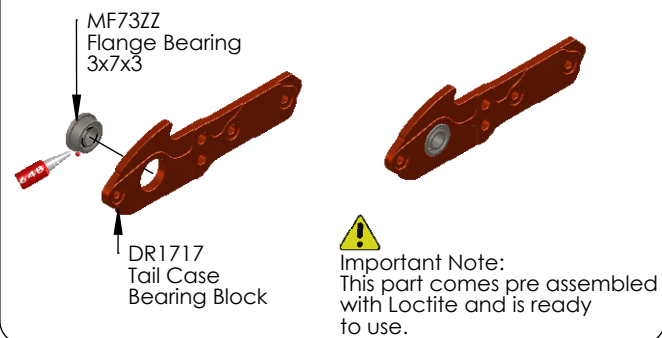

Important Note:
This part comes pre assembled with Loctite and is ready to use.

Pre Tensioner Belt Pulley Assembly.

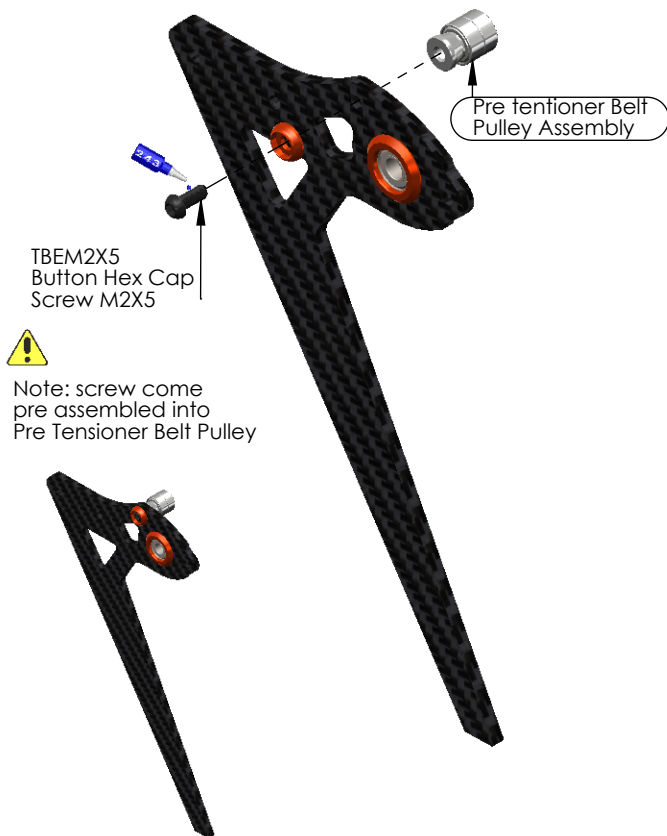

Note: screw come pre assembled into Pre Tensioner Belt Pulley

Bell Crank Assembly. (Box 1 / Bag 5)

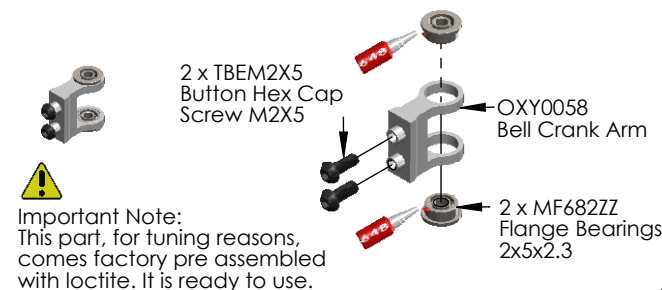

Important Note:
This part, for tuning reasons, comes factory pre assembled with loctite. It is ready to use.

Bell Crank Arm Assembly.

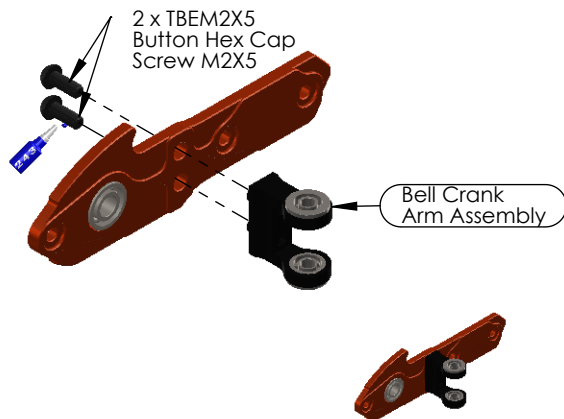

Note: screws come screwed into the Bell Crank Arm

Tail Case Assembly.

Step 1

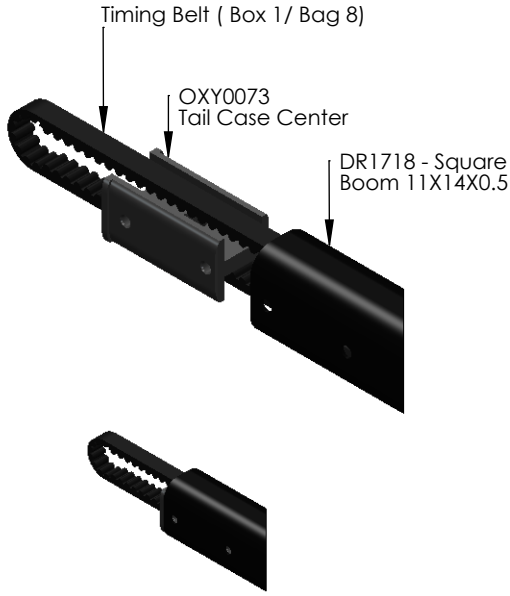

!
Remove the tail case center from the boom, and then feed the belt through the boom. Try not to tightly bend the belt. We suggest using a length of wire or similar to pull the belt through the boom.

Tail Case Assembly.

Step 2

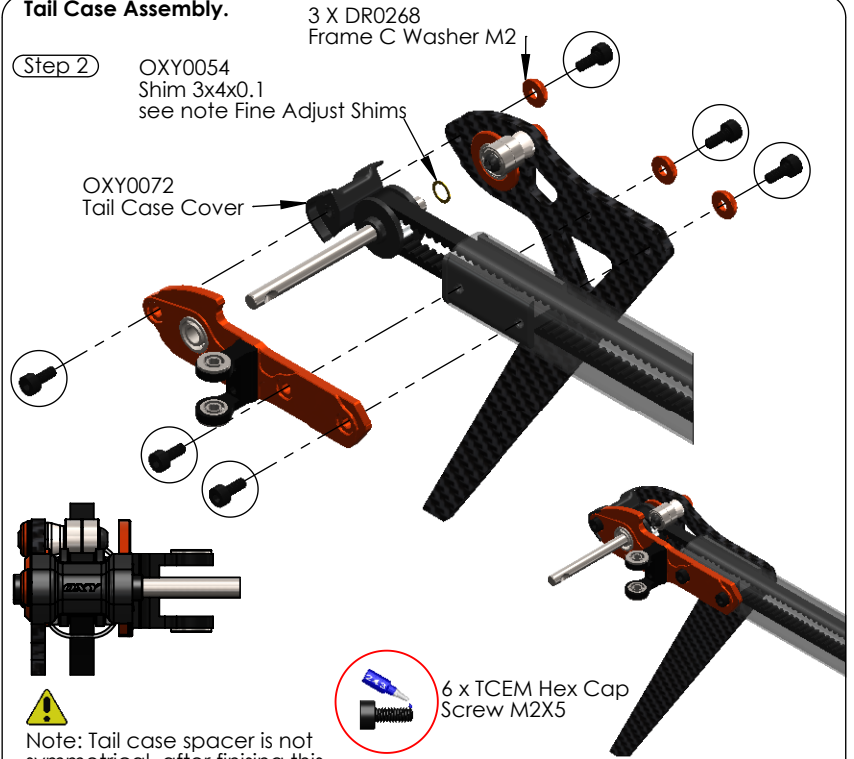

!
Note: Tail case spacer is not symmetrical, after finishing this step Oxy logo's position as shown

!
Note: screw come screwed into the Tail Boom & Tail Case Spacer.

!
Fine Adjust Shims:
In order to give fine adjustment options, in the Extra Hardware Bag you will find extra shims 3x4x0.1 Start assembly without shims. If the Tail Assembly has sideways play, add shims as required, to one side, as shown.

Tail Assembly.

Step 1

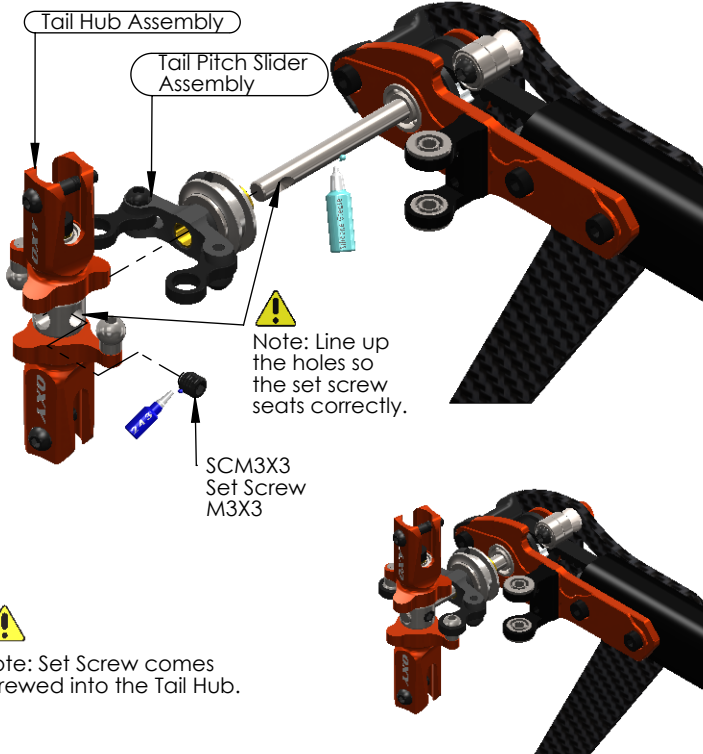

!
Note: Line up the holes so the set screw seats correctly.

!
Note: Set Screw comes screwed into the Tail Hub.

Tail Assembly

Step 2

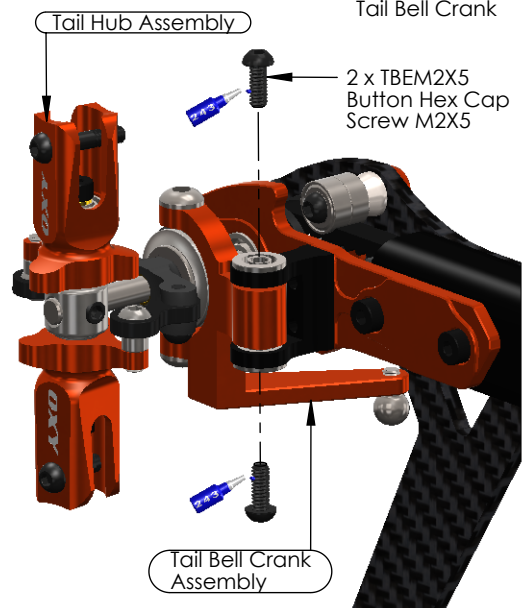

! Note: Screws come screwed into the Tail Bell Crank

!
Important Note:
Once you finish assembly, check the system can slide and move without friction. If tail system is assembled correctly, it should move smoothly and without play. In case of friction or play recheck each single component and re-assembly as required. If necessary adjust the position of the Bell Crank Arm. A common mistake would be allowing loctite to contaminate the bushing and plastic in step 2.

Tail Push Rod Guide Assembly.

Important Note:
This part comes pre-assembled and is ready to use. No loctite required.



Step 1

2 x OXY0068 Pin Screw

OXY0067 Guide Push Rod

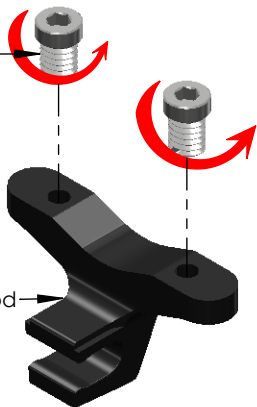

Note: To install this pin screw rotate counter clock wise.

Note Pin Screw Thread: Oxy designed the Pin Screw with a counter clockwise thread. This will help on the final locking operation. Be careful to follow our instructions to get a perfect assembly.

Step 2

Note: Install the Pin Screw and leave a gap as shown.

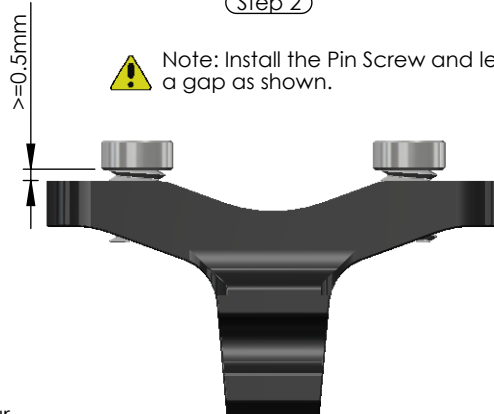

Step 3

Tail Case

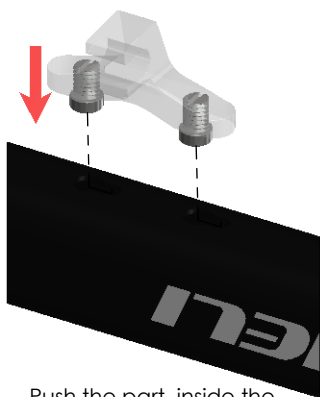

Push the part inside the boom sockets as shown.

Step 4

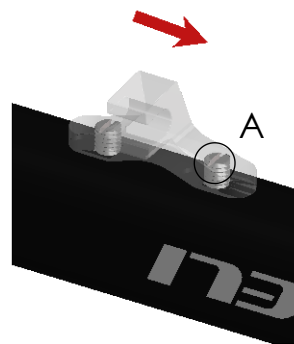

Slide the parts as shown.

Step 5

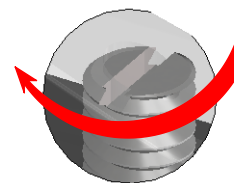

Detail A

In order to lock the tail push rod support, use a Flat Screw Driver and turn clockwise. Do not over tighten.

Carbon Fiber Tail Push Rod Assembly. (Box 2 - Inside Tail Boom)

2 x OXY0011 4mm-Linkage Ball

DR1719 CF Push Rod

2 x DR1076 Tail Push Rod Terminal

2 x OXY0010 Threaded Rod M1.6 X 14

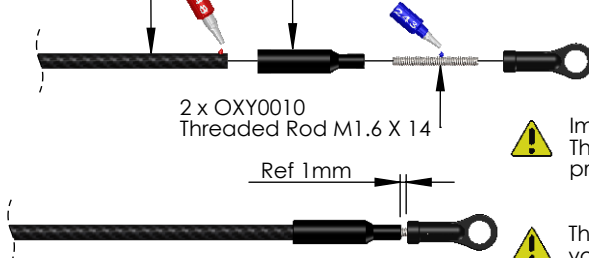
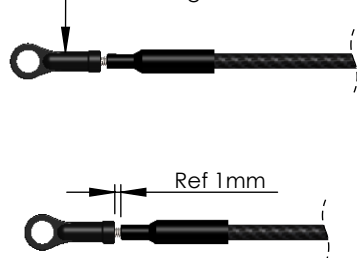

Important Note: The Plastic Terminals and CF Push Rod come pre assembled with loctite. It is ready to use.

Note: The Plastic ball links have a Lynx logo to give you information about the turn adjustment, but have symmetrical ball socket shape and can be installed in either direction to achieve the best fine tuning.

Tail Servo Mount Assembly. (Box 1 / Bag 7)



Follow instruction for final assembly, install WITHOUT over tightening

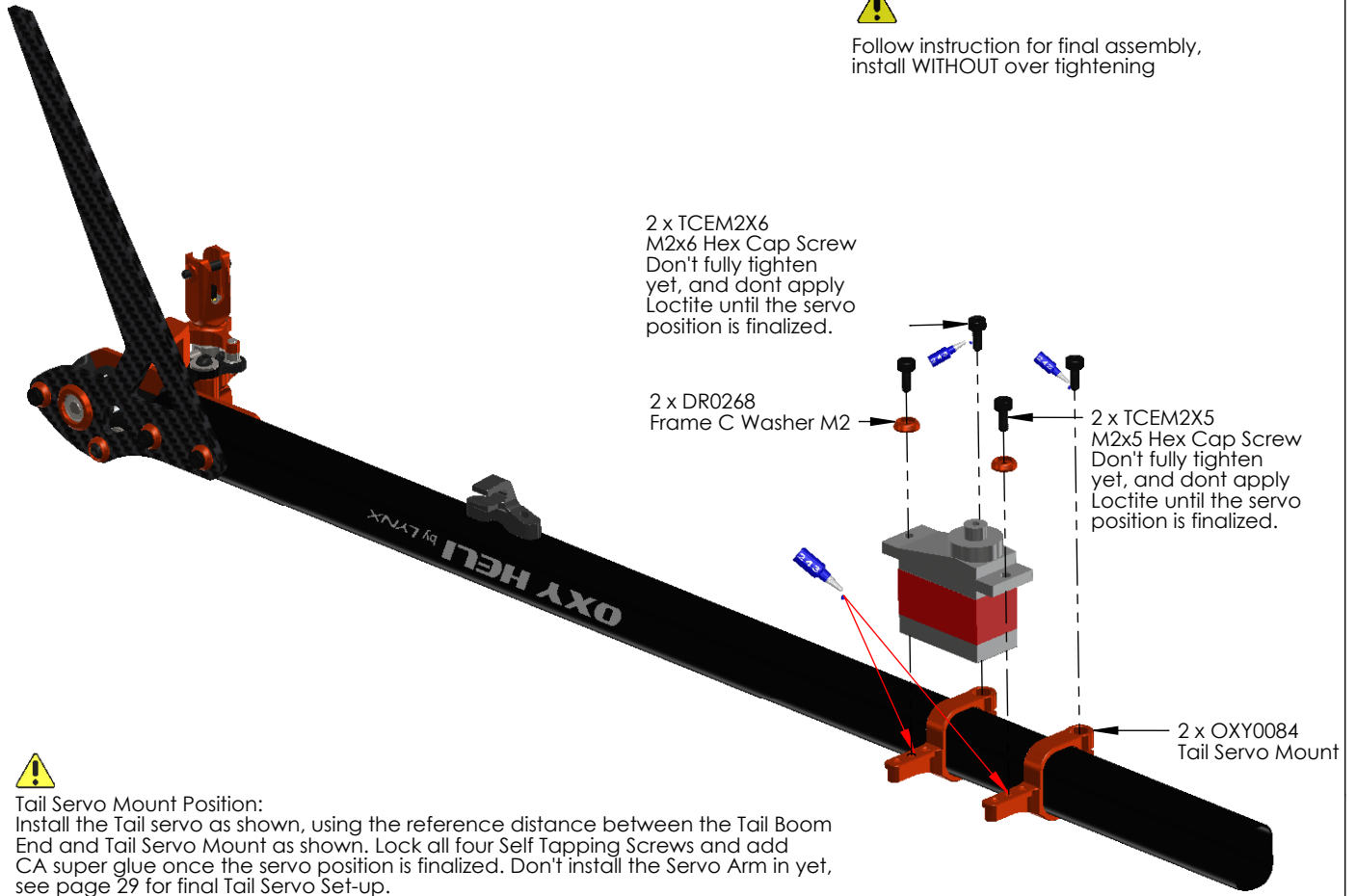

2 x TCEM2X6
M2x6 Hex Cap Screw
Don't fully tighten yet, and don't apply Loctite until the servo position is finalized.

2 x DR0268
Frame C Washer M2

2 x TCEM2X5
M2x5 Hex Cap Screw
Don't fully tighten yet, and don't apply Loctite until the servo position is finalized.

2 x OXY0084
Tail Servo Mount



Tail Servo Mount Position:
Install the Tail servo as shown, using the reference distance between the Tail Boom End and Tail Servo Mount as shown. Lock all four Self Tapping Screws and add CA super glue once the servo position is finalized. Don't install the Servo Arm in yet, see page 29 for final Tail Servo Set-up.



Lower Bearing Block Assembly. (Box 1 / Bag 13)

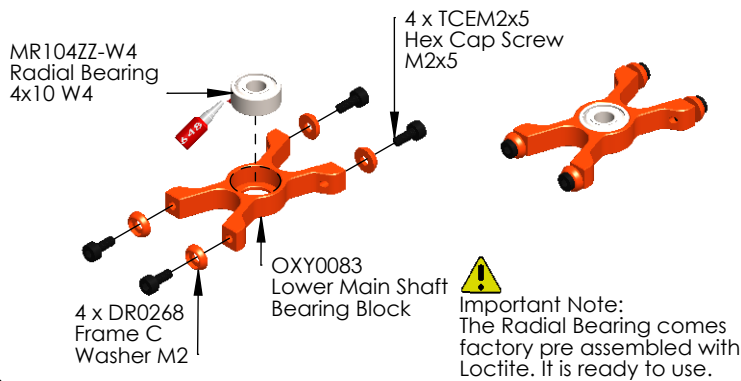

Break Away Canopy Assembly. (Box 1 / Bag 6)

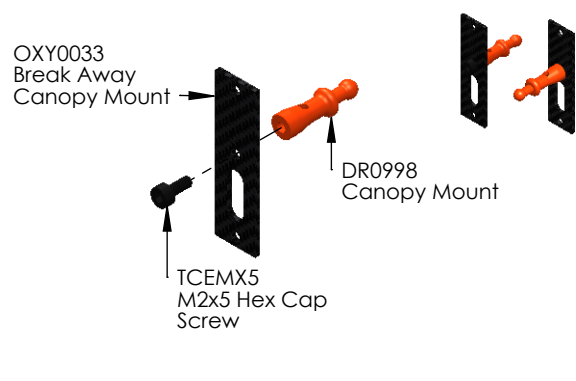

Middle Bearing Block Assembly. (Box 1 / Bag 15)

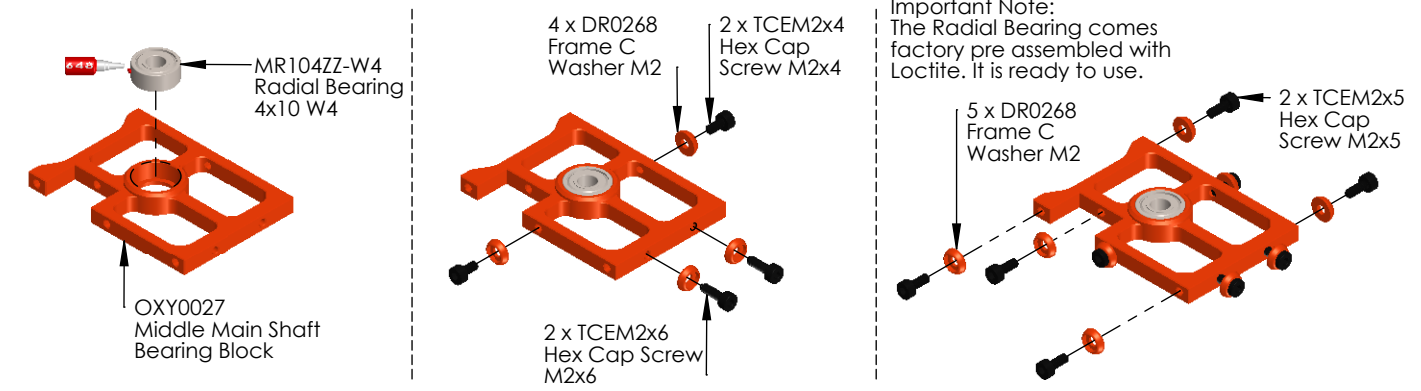

Upper Bearing Block Assembly. Box 1 / Bag 14)

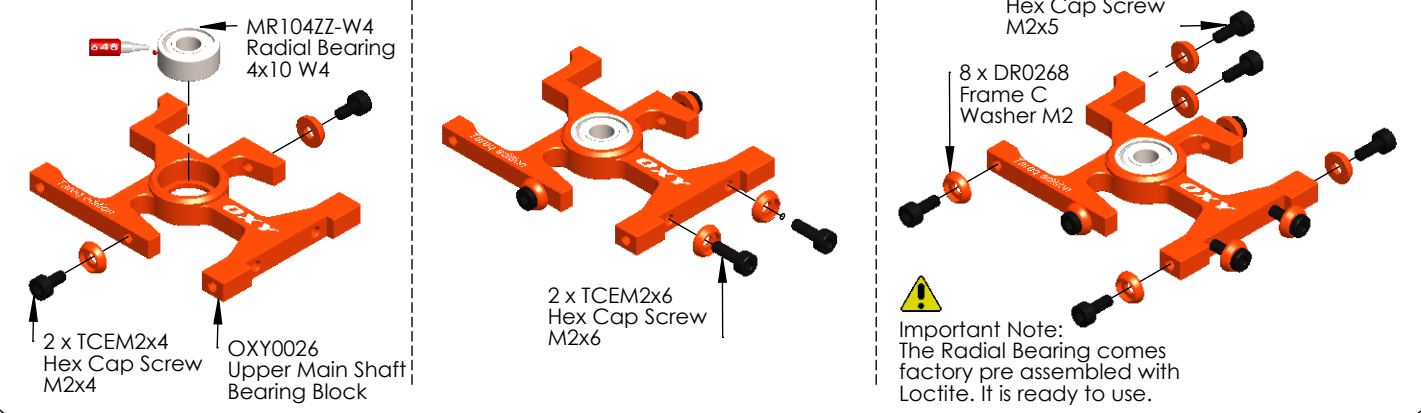

Boom Clamp Assembly. (Box 1 / Bag 16)

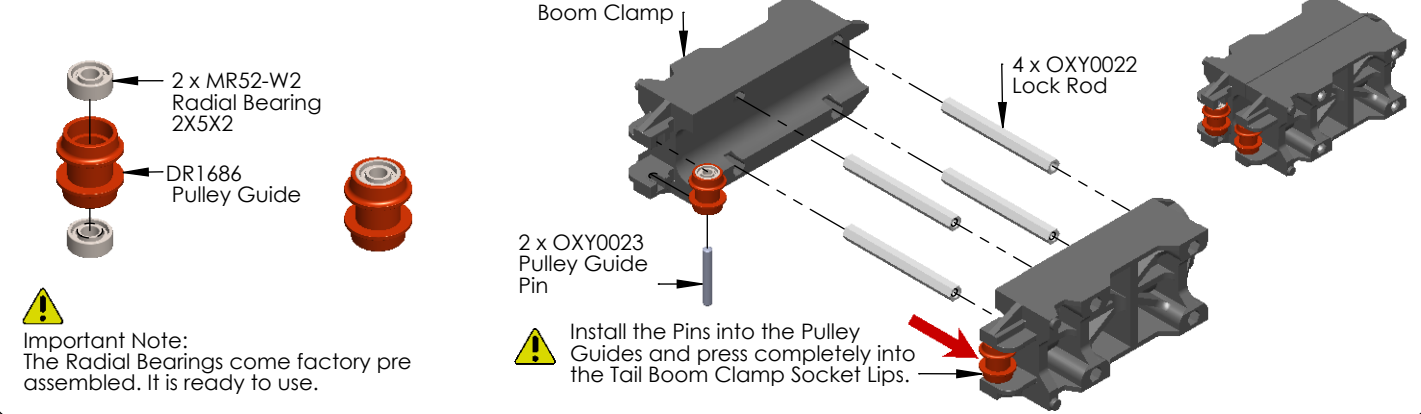

Main Frame Assembly.

(Step 01)

Middle Bearing Block Assembly
Note: Radial Bearing open Face down

Lower Bearing Block Assembly
Note: Radial Bearing open Face up

OXY0035 Battery Tray

OXY0030 Main Frame

Upper Bearing Block Assembly
Note: Radial Bearing open Face up

Break Away Canopy Assembly

2 x TCEM2X4 Hex Cap Screw M2X4

10 x DR0268 Frame C Washer M2

2 x TBES2X6 M2x6 Hex Cap Screw Self Tapping

ESC assembly note:
In order to help the assembly procedure, we suggest to install ESC now. Please refer to Manual page 17, how to install the ESC.

6 x TCEM2X5 Hex Cap Screw M2X5
Note: Don't fully tighten yet. See the assembly alignment note page 14.

Note: Screw come screwed into the 3 x Bearings Blocks.

Main Frame Assembly.

(Step 02)

Boom Clamp Assembly

OXY0029 Motor Mount

OXY0274 OXY3 Motor Mount Stiffener

2 x DR1806 Aluminum Stiffener

4 x TCEM2X8 Hex Cap Screw M2X8
Note: Add Loctite 243 Don't fully tighten yet. See assembly belt and tension note page 23.

2 x TCEM2X6 Hex Cap Screw M2X6
Note: Add Loctite 243 Don't fully tighten yet. Finalize tightening once pinion and main gear mesh are adjusted.

Note: Screw come screwed into the Boom Clamp and Motor Mount.

Main Frame Assembly

Step 03

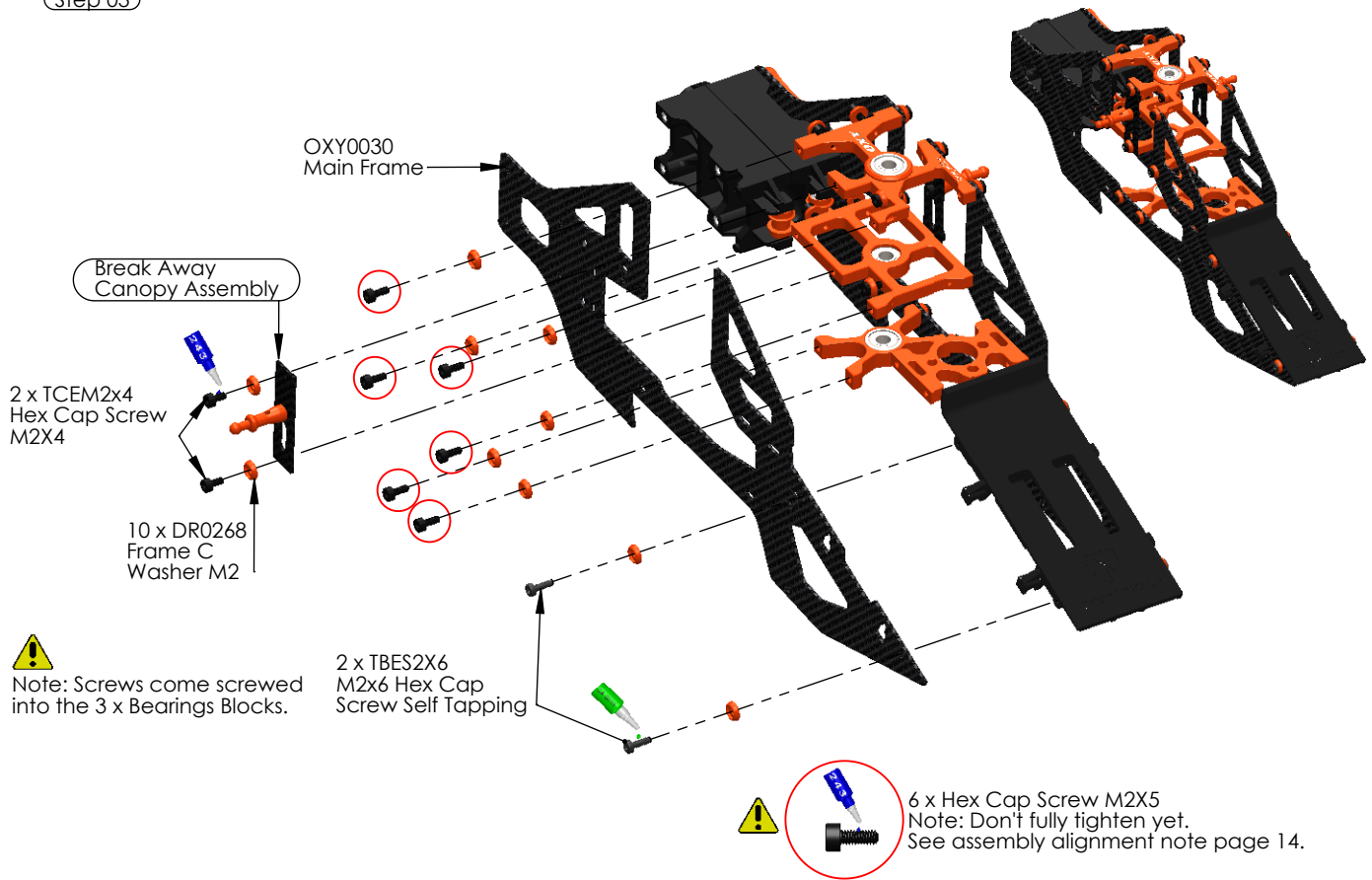

Main Frame Assembly

Step 04

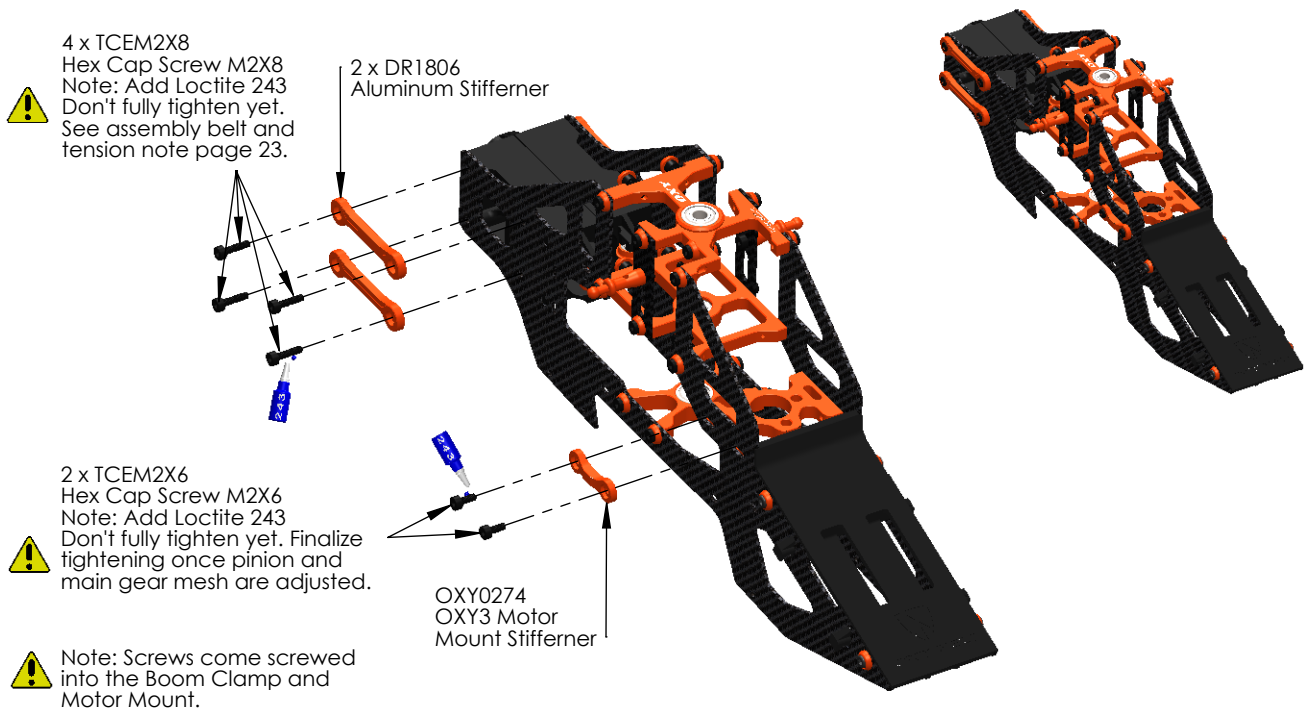

Main Frame Assembly.

Step 05



Install main shaft with frame assembly on a flat surface, push down on both frames together and then fully tighten all M2x5 hex cap screws (x12) holding the bearing blocks.

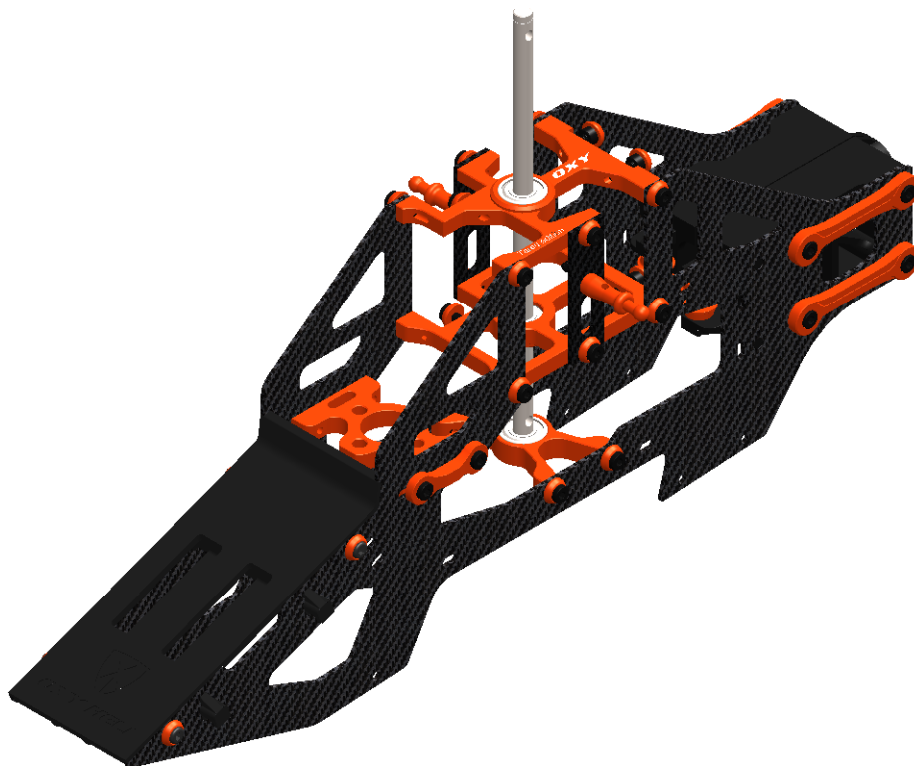
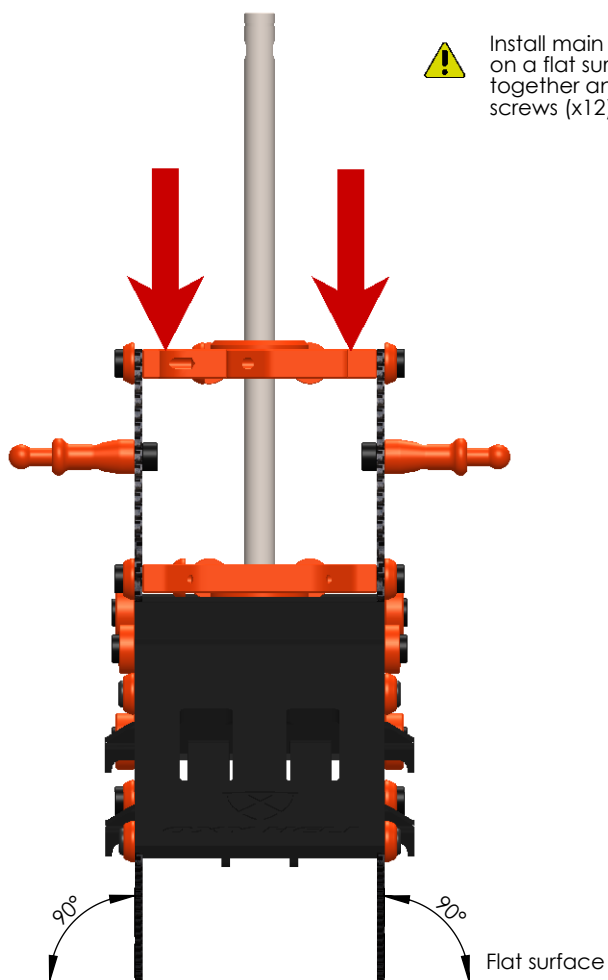

Motor Installation. (Box 1 / Bag 18)



Keep the motor wires pointing forward, and slip them down behind the battery tray when you install the motor.

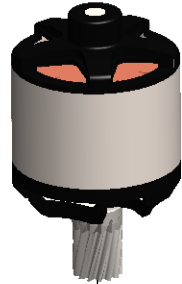

REF 14.5 mm

SCM3X3
Set Screw M3X3



Pinion Installation note:
Be sure the set screw for the pinion tightens down on the 'flat' on the motor shaft.

Oxy 3 Slant Pinion
(11T - 14T Standard)
See page 15 - Table for best pinion choice.

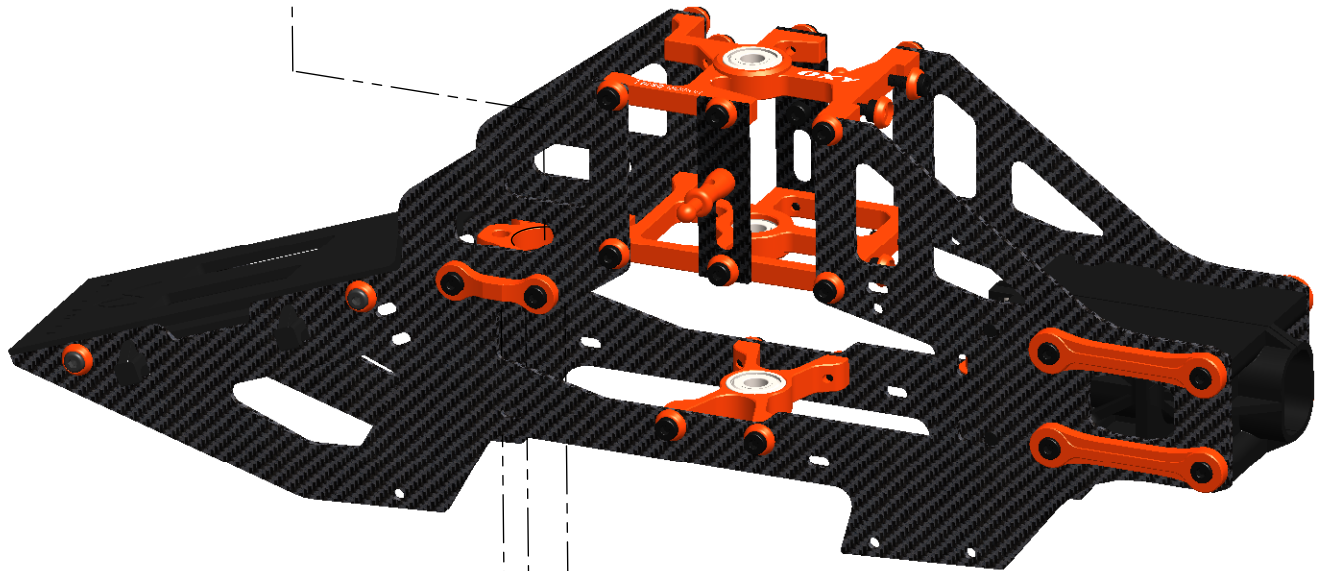

3 x TCEM3X8
Hex Cap Screw
M3X8

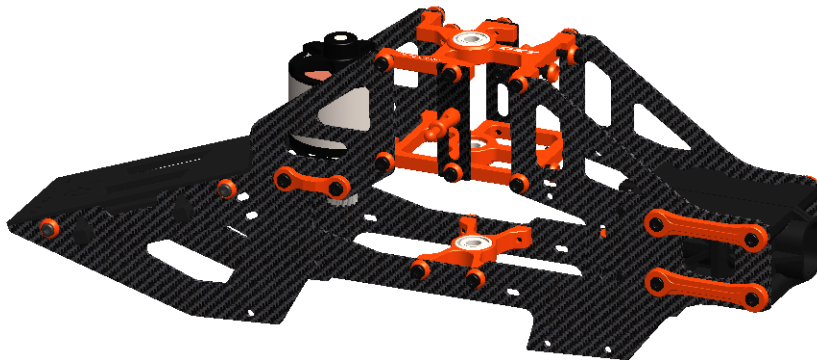
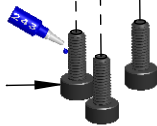

OXY 3 POWER SYSTEM AND HEAD SPEED SET-UP.

In order to choose your best Oxy 3 set up, and optimize performance, it is important to know some important information:

- 1- Motor Kv - (EOX 2214 - 4100 KV Standard Motor)
- 2- Battery Pack - (3s or 4s)
- 3- Your target Head Speed

If you use a head speed calculator that request main gear ratios, use **140 T** for the main gear and select one of the pinion available 10T - 11T - 12T - 13T - 14T - 15T - (Standard Kit come with two pinions 11T and 14T, that ensures a Head Speed Range with 3 and 4S suitable from Novice to Expert Pilot requests.

Oxy 3 available reduction ratios option chart:

Oxy P/N	Description	Ratio	Note
OXY0104	Pinion 10T-M0.5 - 3.17 Motor Shaft	14.000	
OXY0094	Pinion 11T-M0.5 - 3.17 Motor Shaft	12.727	Included
OXY0095	Pinion 12T-M0.5 - 3.17 Motor Shaft	11.667	
OXY0096	Pinion 13T-M0.5 - 3.17 Motor Shaft	10.769	
OXY0042	Pinion 14T-M0.5 - 3.17 Motor Shaft	10.000	Included
OXY0086	Pinion 15T-M0.5 - 3.17 Motor Shaft	9.333	

Oxy 3 Fly Style / Head Speed / Main Blade / Tail Blade / Max Pitch suggestion chart:

Fly Style	Head Speed	Main Blade	Tail Blade	Max Pitch
Hover	2500/3000	245 Plastic	50	+ 10 / -3
		255 CF		
Fly 2D	3000/3500	245 Plastic	50	+ 10 / -5
		255 CF		
Soft 3D	3000/3500	250 CF	50	+/-12
		255 CF		
Hard 3D	3500/4000	250 CF	47	+/-14
		255 CF		
Extreme 3D	4000/4500	250 CF	47	+/-14
		255 CF		

Head Speed Note: Although Oxy 3 can handle very high Head Speed, we suggest don't exceed 4500 RPM to maintain a good compromise btw performances and efficiency.

Configuration examples

Since the Oxy 3 is a high performance 3D RC helicopter, we suggest using high quality power components including motor, battery and ESC. Remember the Oxy 3 is a 300 class heli - use light components to maximize flight time and performance.

Here are some suggestions:

- Motor: Suggested KV 3000KV to 4500KV, 21-08 to 22-14 caliber series (stator diameter - stator length).
- Battery: 3 or 4S with capacity from 1300 to 1500mAh / 35C discharge rate. Maximum size: length 76mm, height 35mm, width 37mm, weight 180g.
- ESC: 35 to 40A - with BEC 6V or higher. Or use an external 5A BEC. The Oxy 3 Kit 002 comes with a 40A ESC, preset with 6V BEC and settings for the EOX 2214-4100KV motor.
- Cyclic servos: Standard MICRO size servo with metal gear - speed: =>0.06 sec/60 at 6V.
- Rudder servo: Standard MICRO size servo - speed =>0.06 sec/60 at 6V - a specific rudder servo is suggested for best tail authority.
- FBL system: The Oxy 3 was designed around the Ikon / Brain and Mini V-Bar Systems. But many other good quality FBL systems can be used, depending on your personal choice.
- Main blade: The Oxy 3 can fly with plastic or CF main blades from 245 to 255mm. Our testing was with Lynx 245mm plastic main blades, and Zeal 250mm and 255mm CF main blades. The Oxy 3 main grips use M2 clamp screw and have a 5.6mm root.
- Tail blades: The Oxy 3 uses our own OEM tail blades, either 47 or 50mm (included with the kit). They use a M2 clamp screw and 3.5 root.

We offer 47 and 50mm tail blades to suit different head speeds. Use 50mm tail blades when your head speed is lower than 3500rpm and 47mm with higher head speeds.

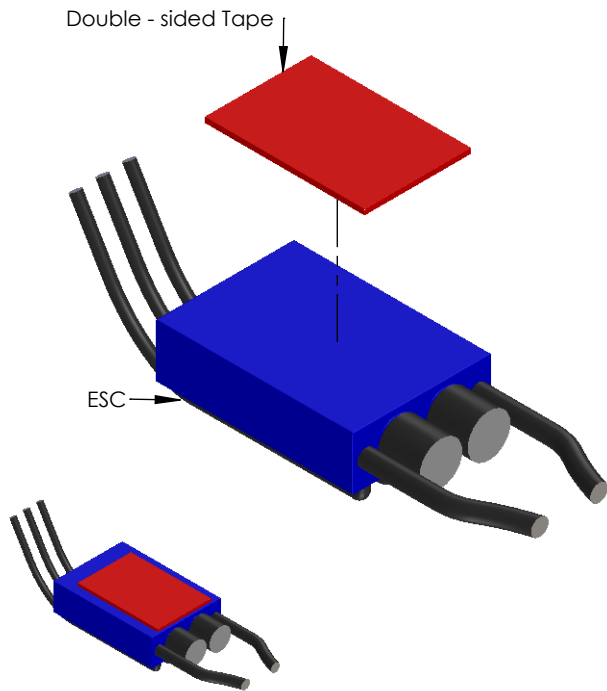
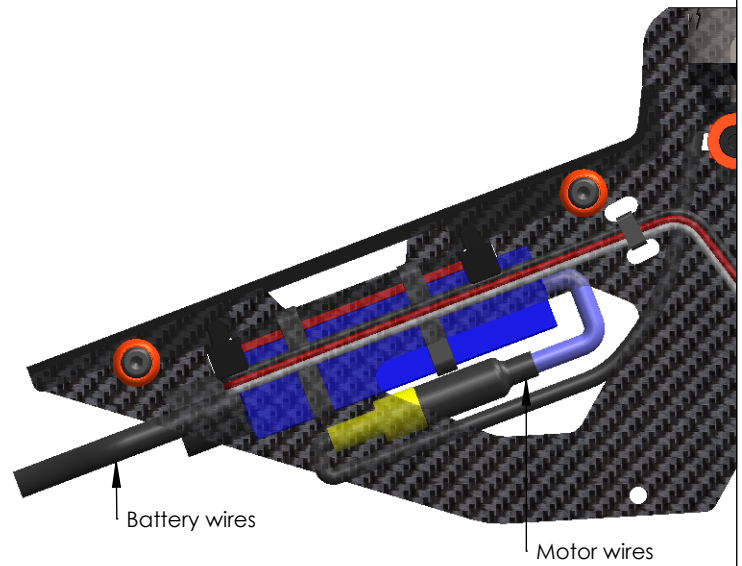
Step 1 Accessories Bag**Step 2**

Install the ESC as shown, and secure with cable ties (2.5mm).

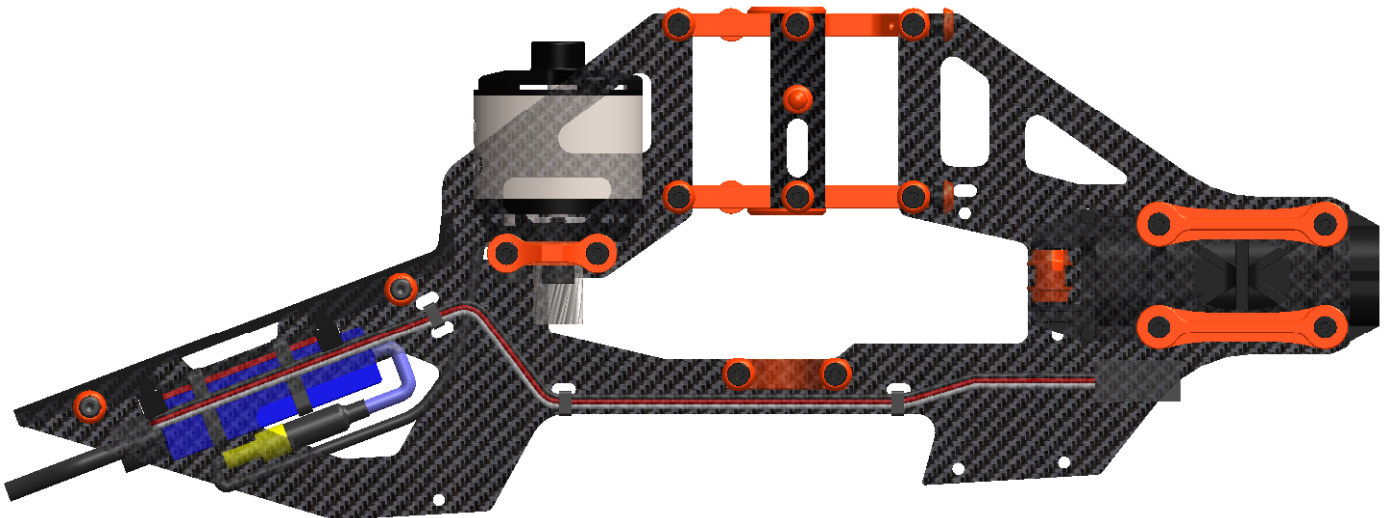
Step 3

- ⚠** Use 3 x cable ties, to secure the Throttle ESC wire to the main frame. Use the Frame built-in socket for best holding. In this Step connect the Motor and ESC Wires but don't secure yet. Wait till the final motor rotation check, once the FBL system is set up.
NOTE: To reverse Motor rotation direction , just switch 2 of the 3 wires.

Step 1

 The FBL system can be installed at the bottom or top of the boom clamp. We suggest to use the bottom for easy wiring and servo removal.

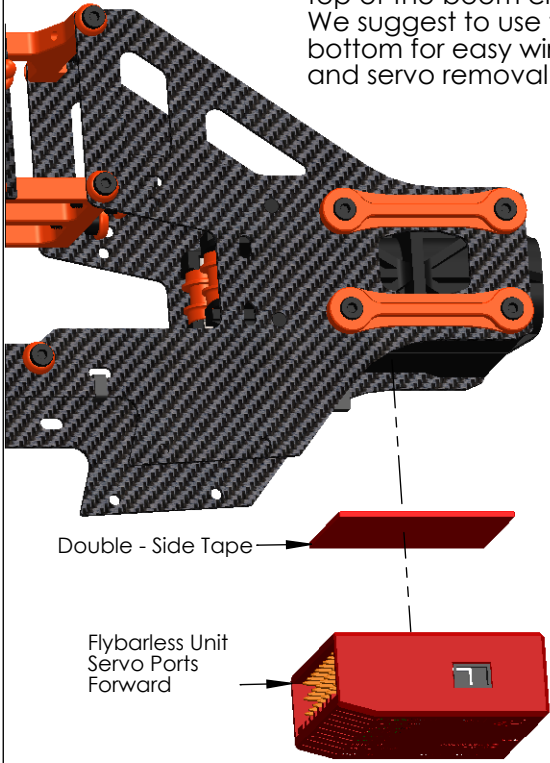

Step 2

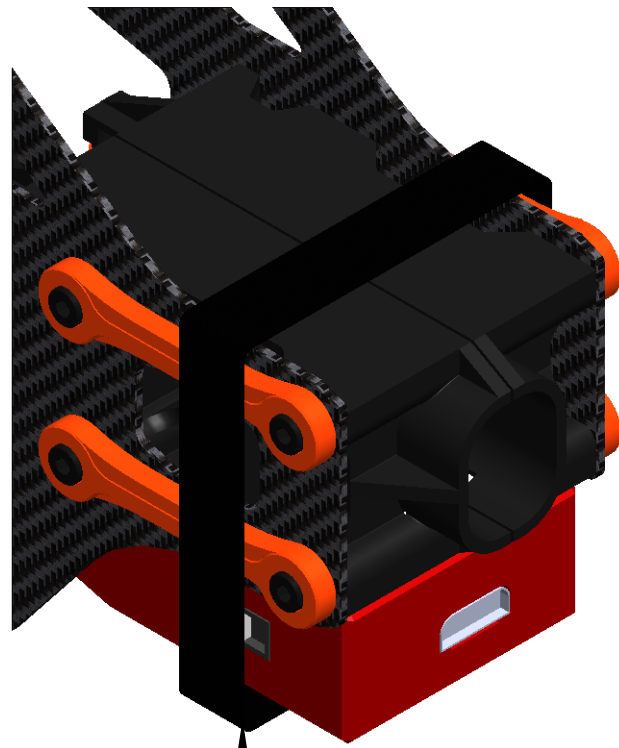

For extra FBL support we suggest to add Electronic Hook and Loop as shown.

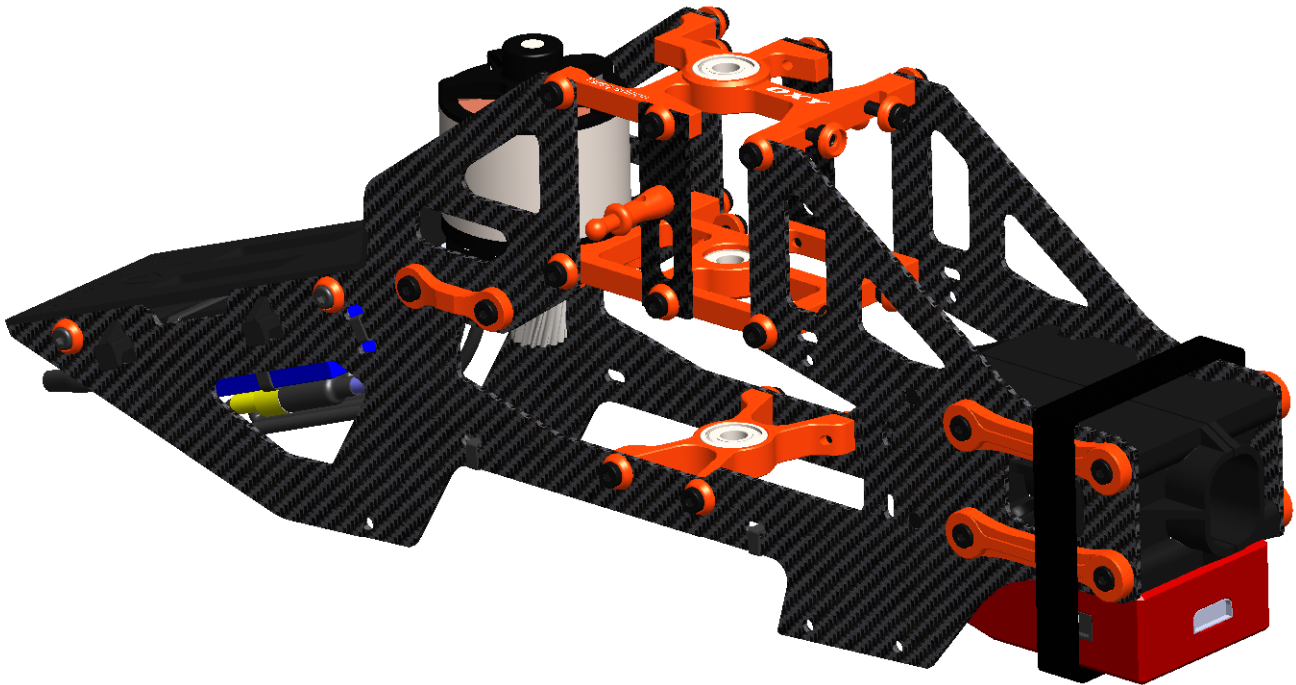

One Way Hub Assembly. (Box 1 / Bag 20)

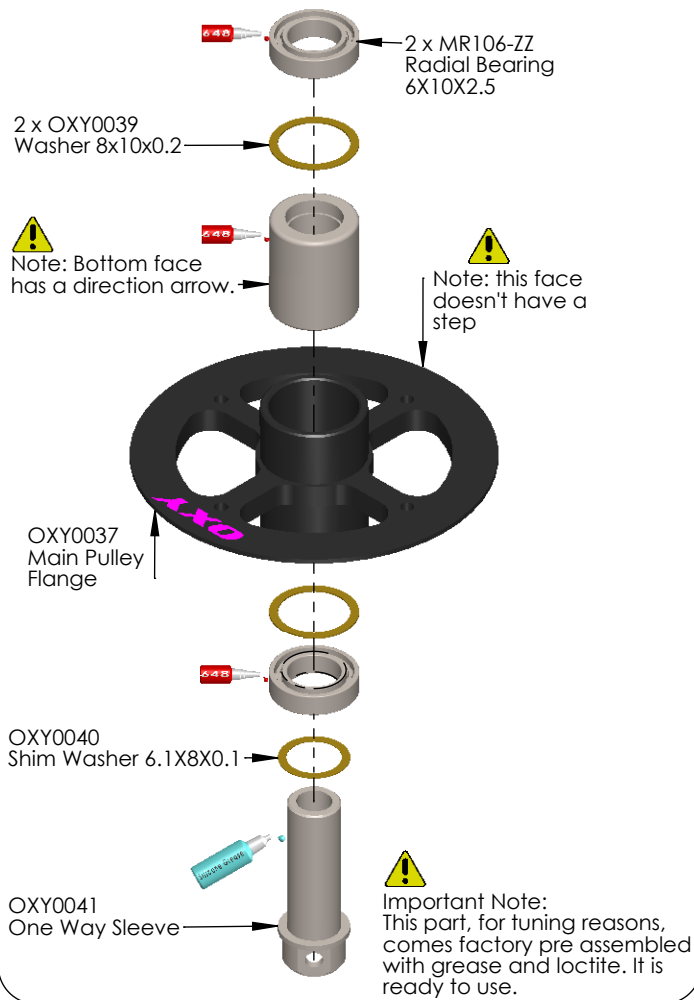

Main Gear Assembly.

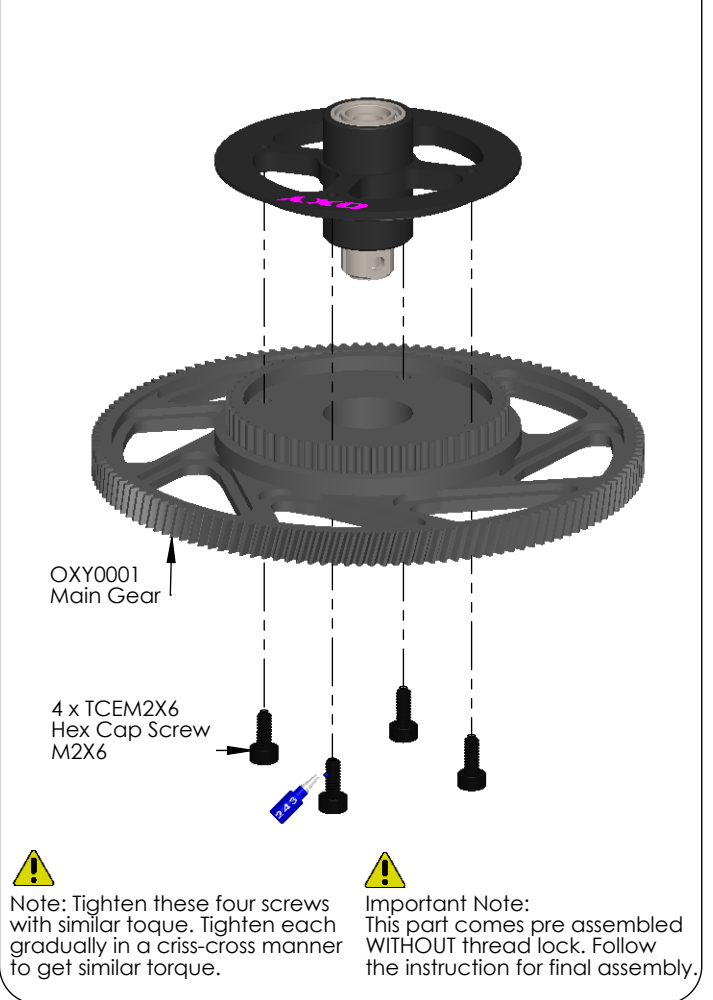

One Way System Direction Check.

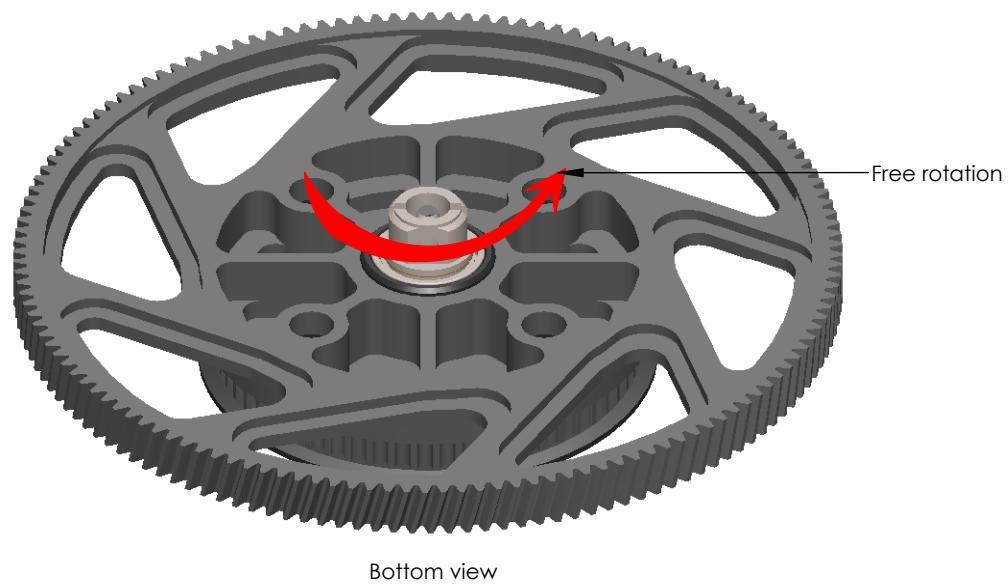

Important Note: use one way sleeve to check the rotation direction of the one way bearing as shown

Belt Adjustment.**Step 1**

Rotate belt as shown



In this picture the tail belt is shown straight coming from the tail pulley. Be careful to check the belt is not twisted inside the boom. Use a light to check inside the boom. Then be sure to rotate the belt 90 degrees as shown. When holding the boom with the tail case away from you, rotate the belt 90 degrees counter clockwise.

Belt Adjustment.**Step 2**

Hold carefully Tail Belt as shown and insert OXY0450-OXY3 Front BoomInsert (Box 1) Press this insert parts into Tail Boom to help Tail Belt doesn't twist in the next installation step

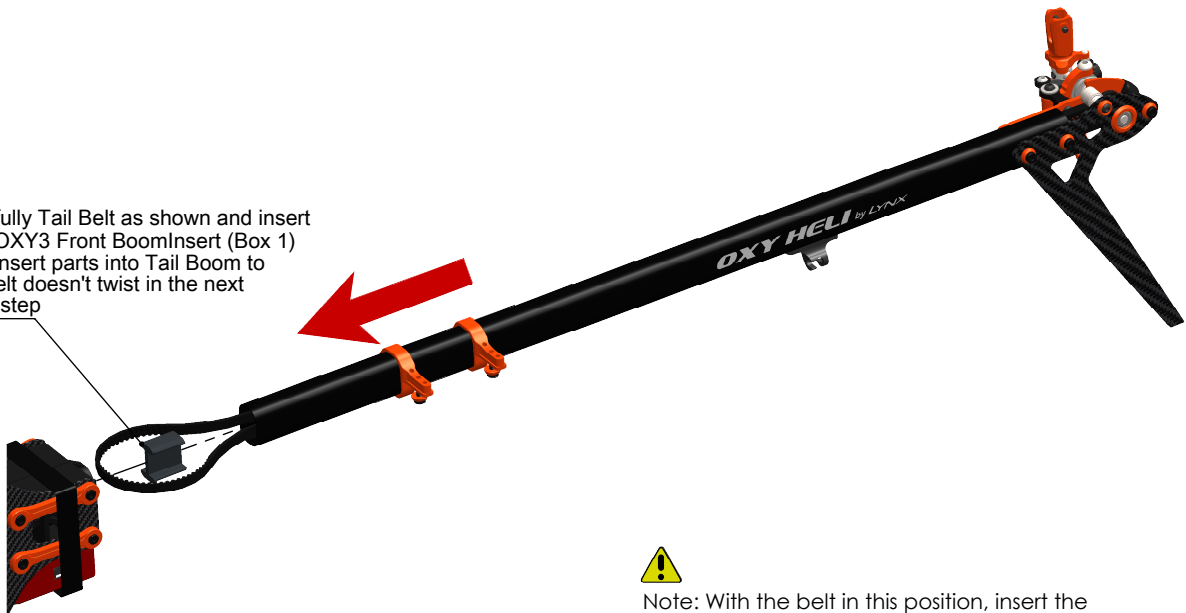

Note: With the belt in this position, insert the tail boom and finalize assembly following the next step. Loosen the Tail Boom Clamp screws for easy insertion.

Install Main Gear, Main Shaft into Main Frame. Box 1 / Bag 11



This hole install with center hub

This hole install with main gear

5 mm

6.9 mm

OXY0003
Main Shaft



Note: In order to help installation and locking Jesus Bolt use small pliers to hold Lock Nut M2 during install.

Lock Nut M2

OXY0038
Auto Rotation Spacer
See Position Note

OXY0076
M2X10 Shoulder
Hex Cap Screw



Note: Auto Rotation Spacer's position:

Top Surface

Bottom Surface

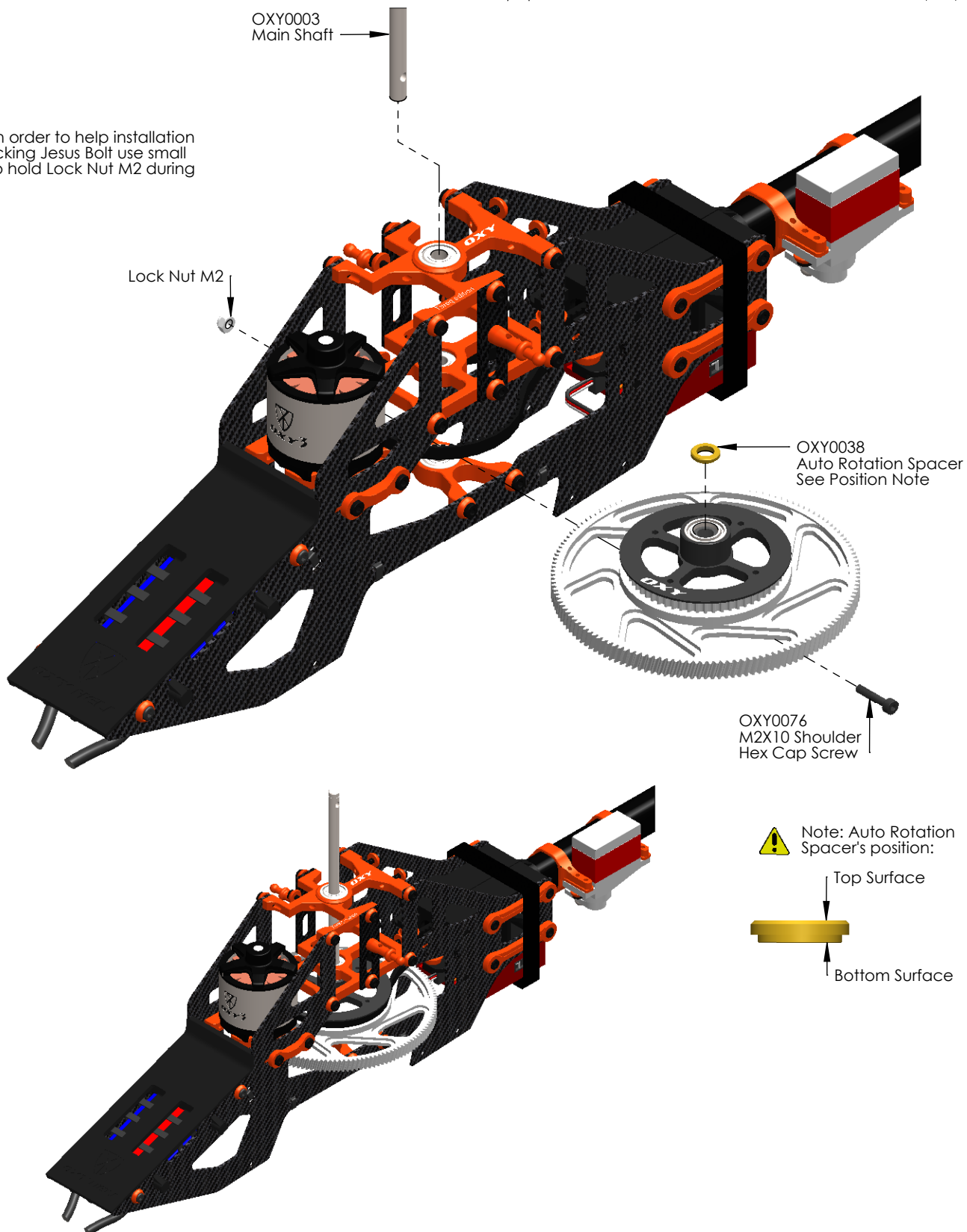

Install Main Shaft Lock Ring into Main Shaft.

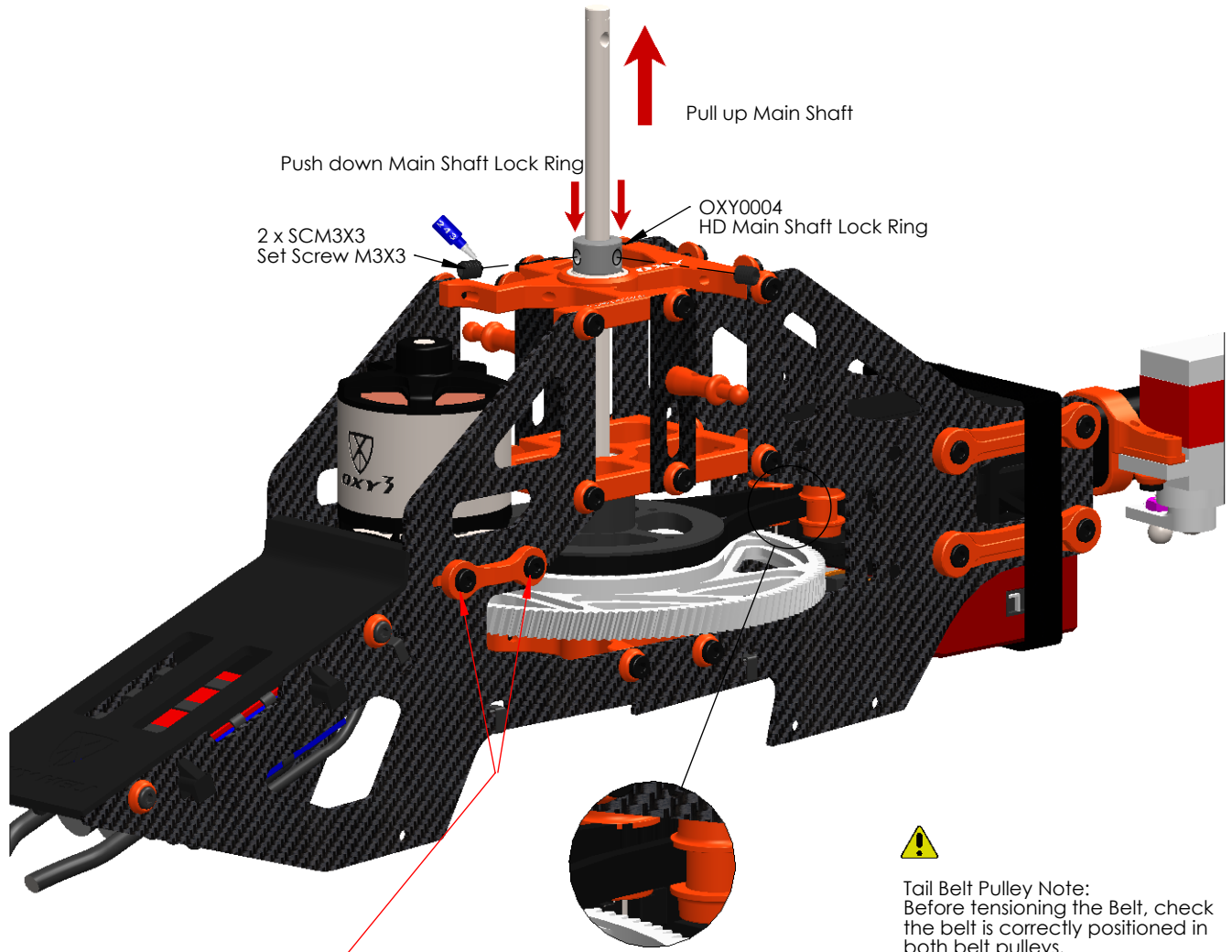

Tail Belt Pulley Note:
Before tensioning the Belt, check the belt is correctly positioned in both belt pulleys.



Once the Main Shaft is secured, adjust the Main Gear mesh and lock the Motor Mount. The Pinion and Main Gear must have a little play. Don't use the paper system to set the mesh, as there will be too much play. Adjust the mesh so there is only a very small amount of play. Before tightening completely the Motor Mount, test the play all around the Main Gear. e-adjust so the correct mesh is set at the tightest point. To increase system efficiency the main gear must rotate freely without binding.

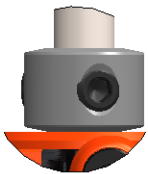

DETAIL A



DETAIL B

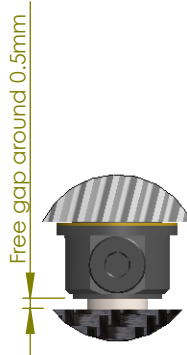

DETAIL C

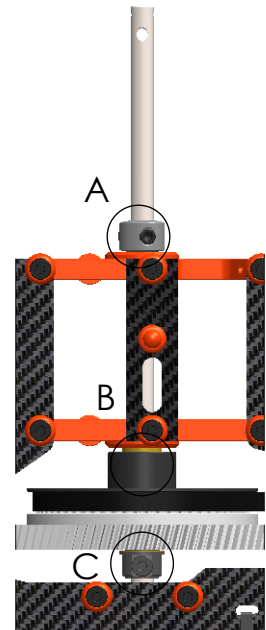

Belt Tension.



Belt Tension Note:

- Be sure the boom is assembled and installed correctly.
- Loosen the tail boom by loosening the eight M2x8 hex cap screws.
- Adjust the belt tension by pulling on the tail boom
- Tighten the eight M2x8 hex cap screws.
- The belt must have good tension. We suggest re-checking after a few flights. We suggest to check belt tension often, before each flying session.
- If the belt is often loose, you should check the lock system or belt integrity.
- Tests show that a hard 3D pilot can perform over 400 flights before the belt will fail. We recommend replacing the Tail Belt after 300 flights, even if it does not show wear, to avoid it breaking unexpectedly in flight.
- After a crash, spend some time checking Belt integrity and replace if any teeth are missing.

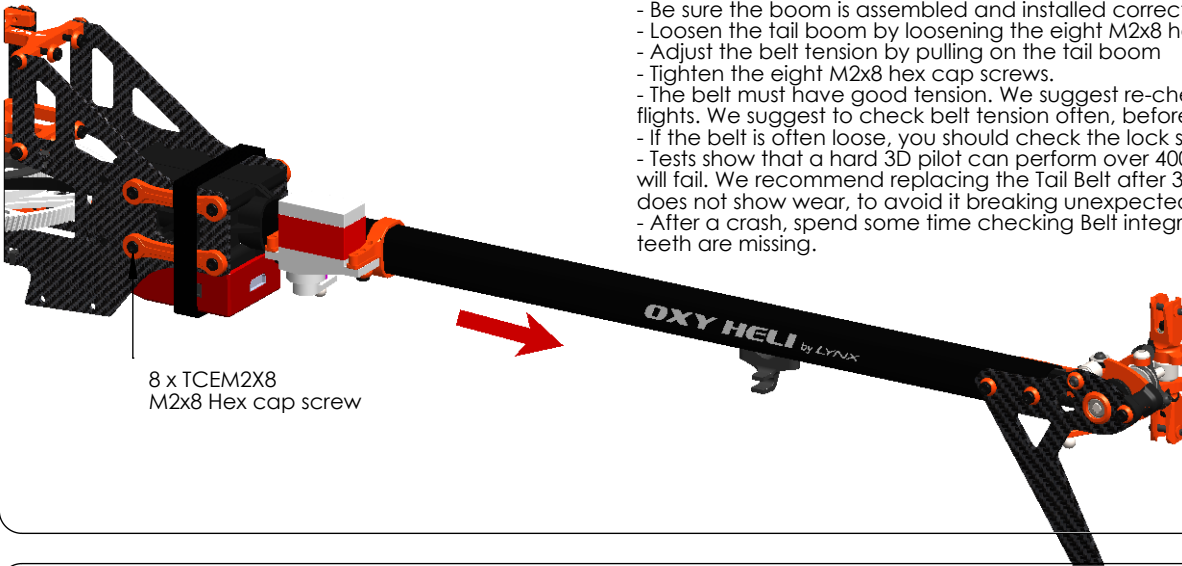

8 x TCEM2X8
M2x8 Hex cap screw

Belt Tension Check.

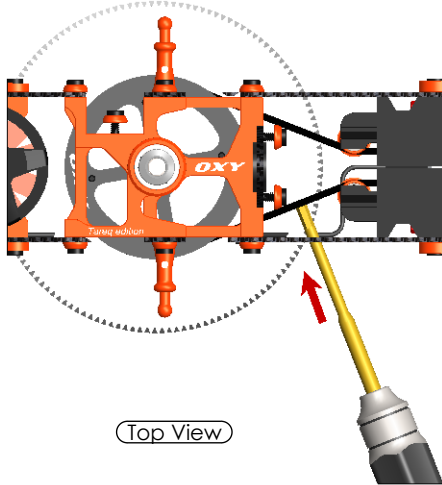

Top View



- Use a Screw Driver to check Belt Tension (suggested max deflection is 1mm)
- Note: We recommend a tight belt tension.
- Check the belt tension again after the first 2 flights.
- With a new Tail Belt, when the head is rotated slowly, it is normal to hear a tooth sound as the belt engages with the Main Pulley. This sound is normal and will disappear after a few flights and the necessary "break-in".

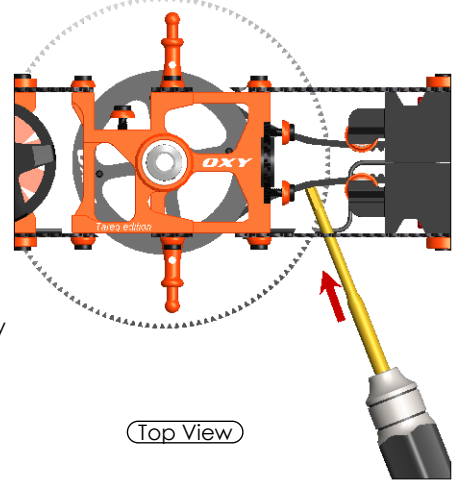

Top View

Tail Rotor Rotation Direction Check.



In order to check the belt installation, we recommend to follow two simple steps:

- 1- Check with light, look inside the boom from the tail case and check the belt is only twisted 90° degrees.
- 2- Rotate the main gear in the flight direction (as shown) and check the tail hub rotates in the direction shown. If the Tail Rotor rotates in the wrong direction, go back to the previous instructions and double check your work.

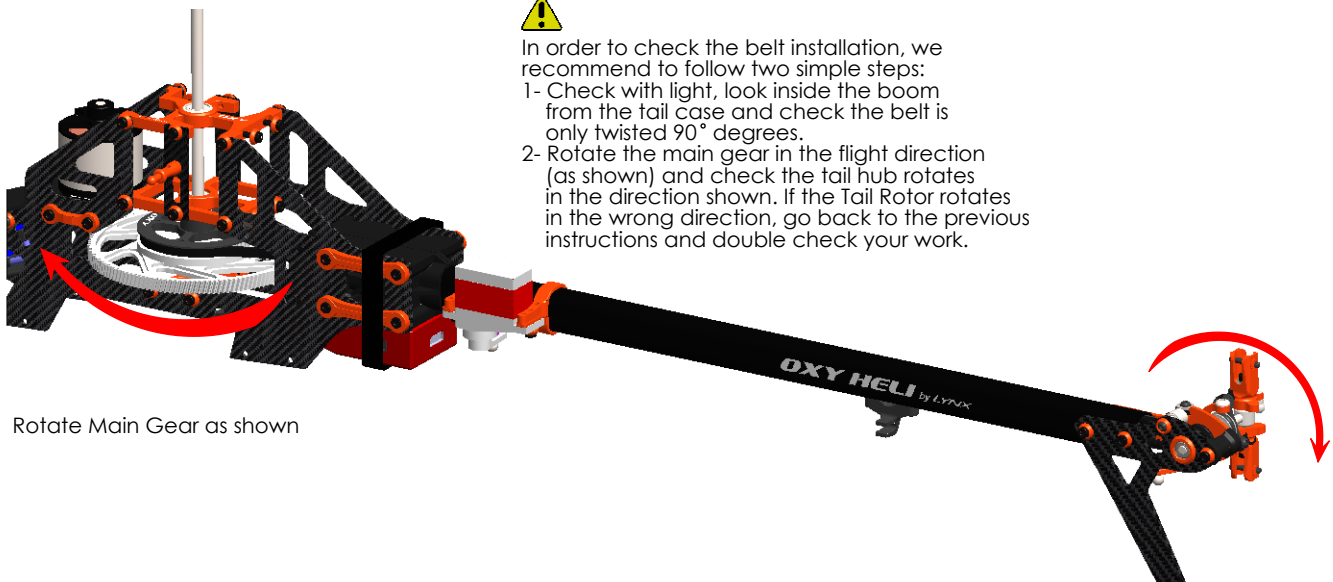

Rotate Main Gear as shown

Head Assembly. (Box 1/ Bag 9)

Step 1

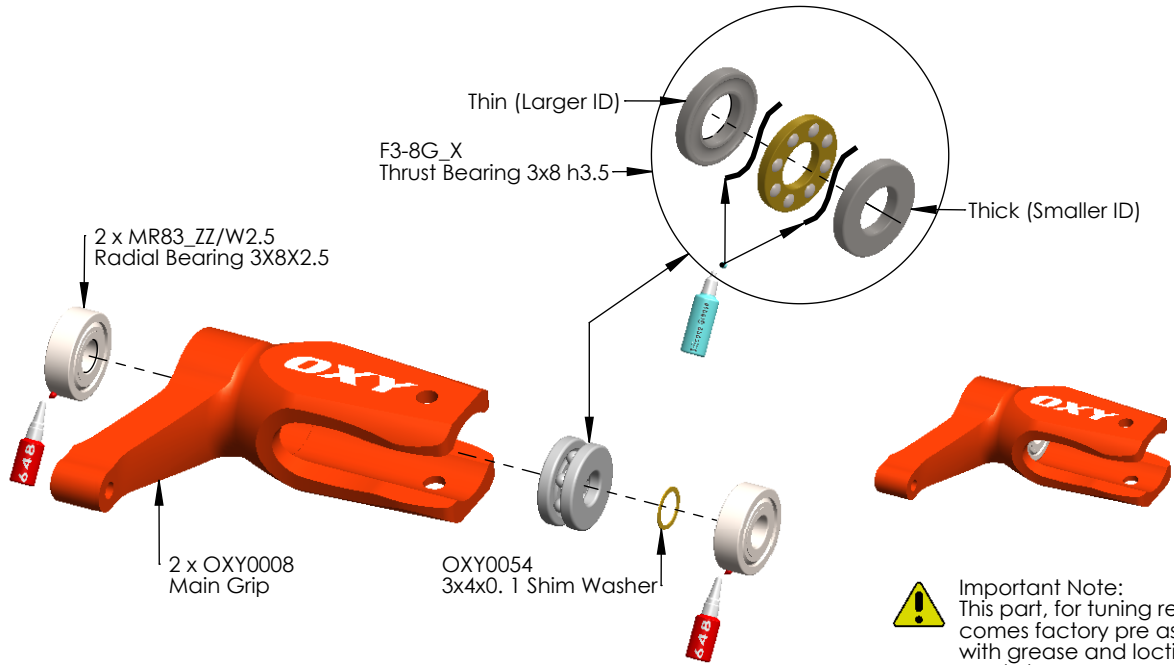

Step 2

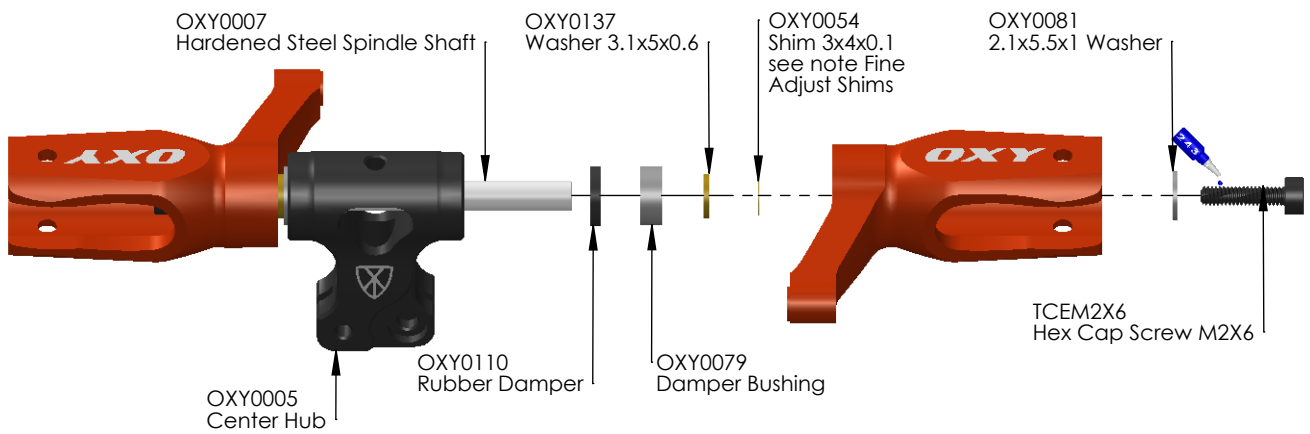

! Important Note: This part comes pre assembled WITHOUT thread lock. Follow the instruction for final assembly.

! Fine Adjust Shims: In order to give fine adjustment options, the extra Hardware Bag contains extra Shims 3x4x0.1. Start assembly with factory pre installed shims. If the Main Grips have sideways play, add shims as required. Each Grips must have the same number of shims. If you add one shim on the left side, you need to also add one shim on the right side.

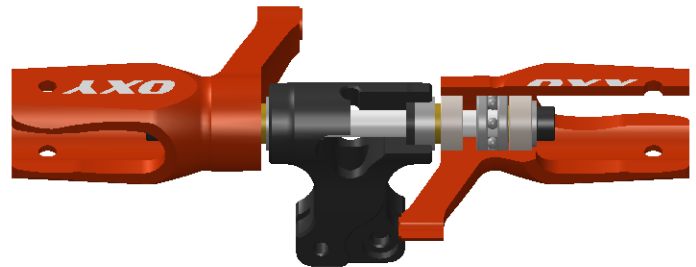

Swash Plate Assembly. (Box 1/ Bag 13)

Step 1

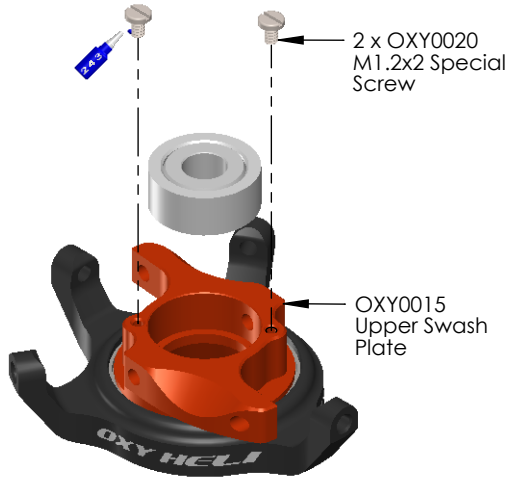

Important Note:
This part, for tuning reasons, comes factory pre assembled with loctite. It is ready to use.

Step 2

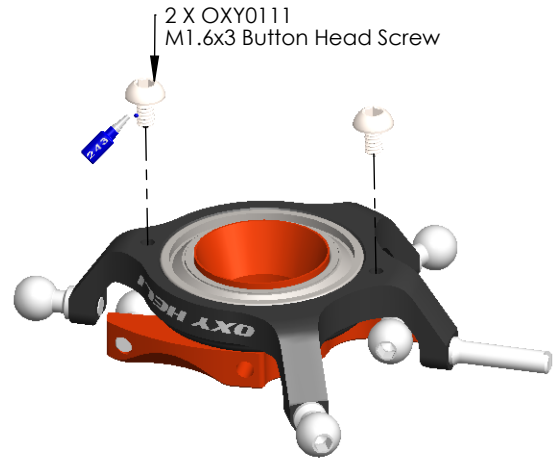

Important Note:
This part, for tuning reasons, comes factory pre assembled with loctite. It is ready to use.

Step 3

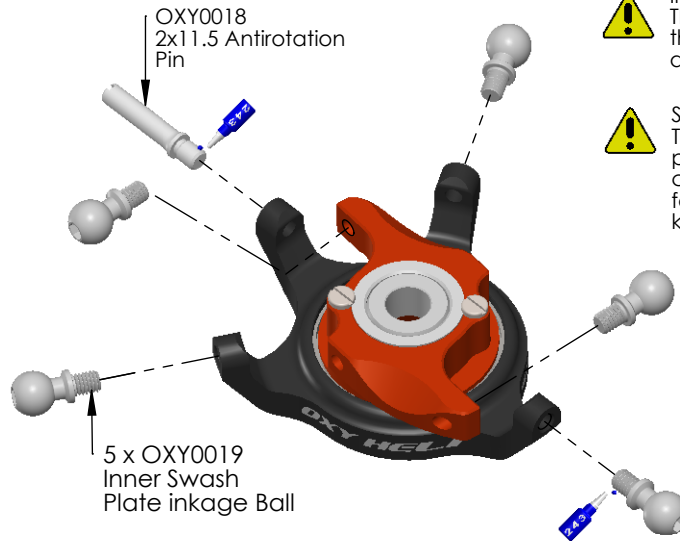

Important Note:
This part comes pre assembled WITHOUT thread lock. Follow the instruction for final assembly.

Swivel Ball Note:
The Swivel Ball is pre-assembled with a precise fitting. When new, the Swash Plate center ball will have a little friction. After a few flights and "break-in" it will come smooth, keeping the best precision without play.

DFC Arm Assembly.

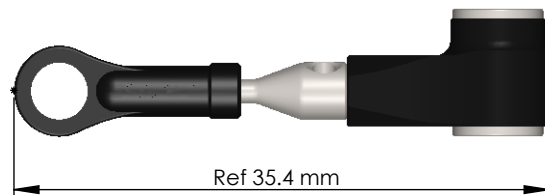
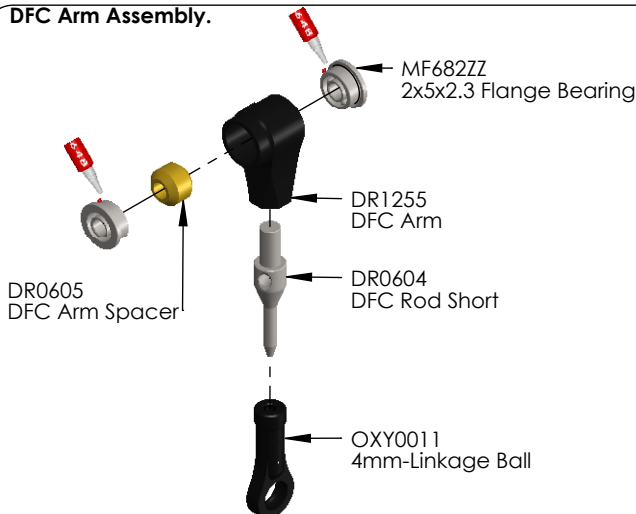

Important Note:
The Oxy Plastic ball links have a logo to give you information about turn adjustment, but have a symmetrical ball socket shape and can be installed in either direction to achieve the best fine tuning.

Head Assembly.

Step 3

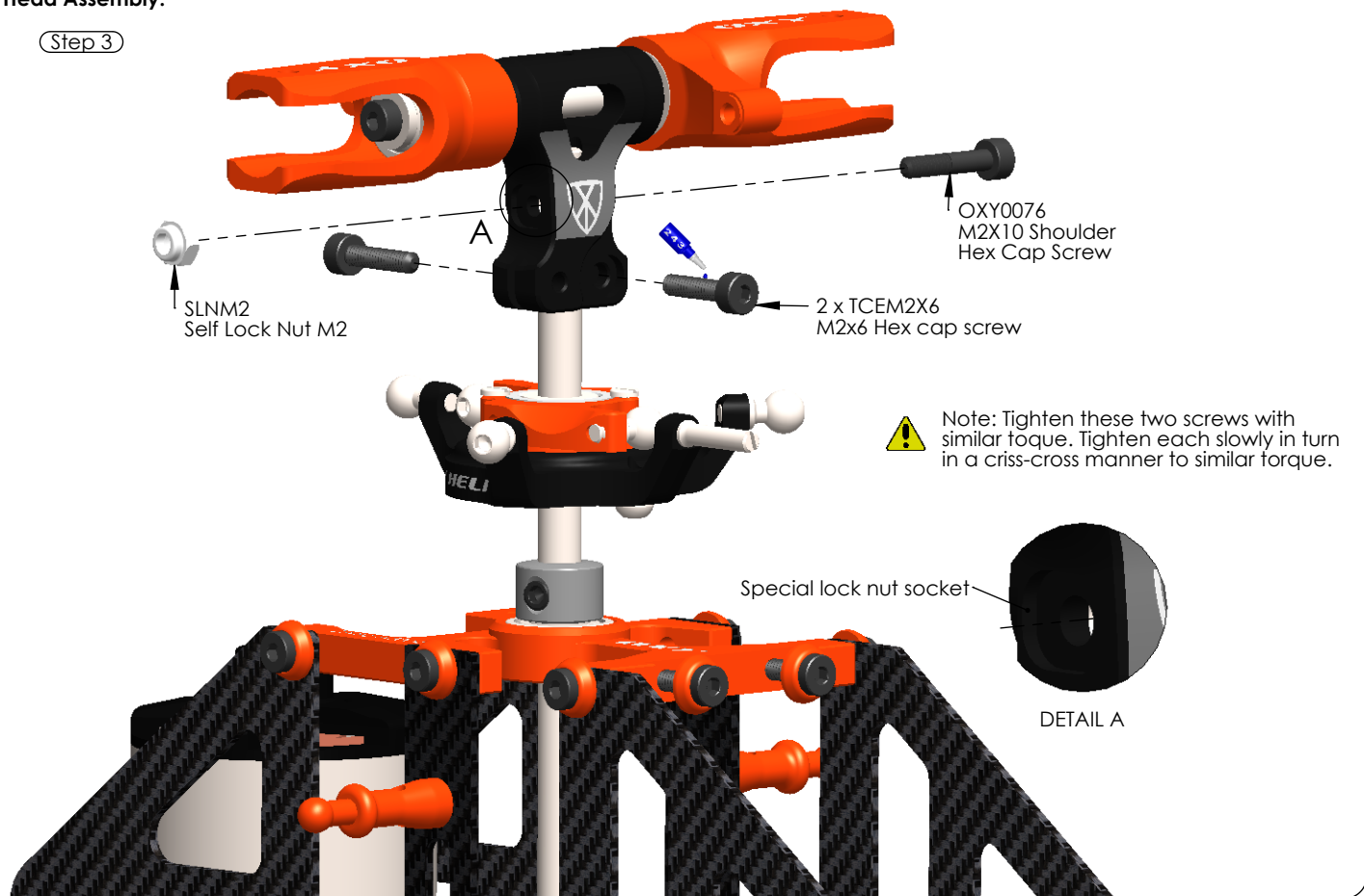

Step 4

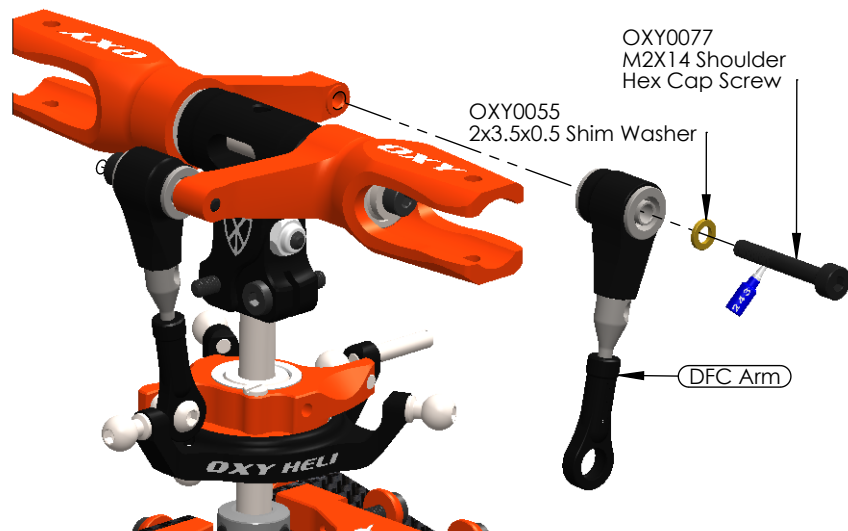

Once you finish assembly, ensure the DFC Arms can rotate without friction. If the DFC Arms are assembled correctly, rotation should be smooth and without friction. In case of any friction, recheck each component and re-assembly as necessary.

Hybrid Head System. (Box 1 / Bag 23)

 Oxy Heli supply another option for FBL head.

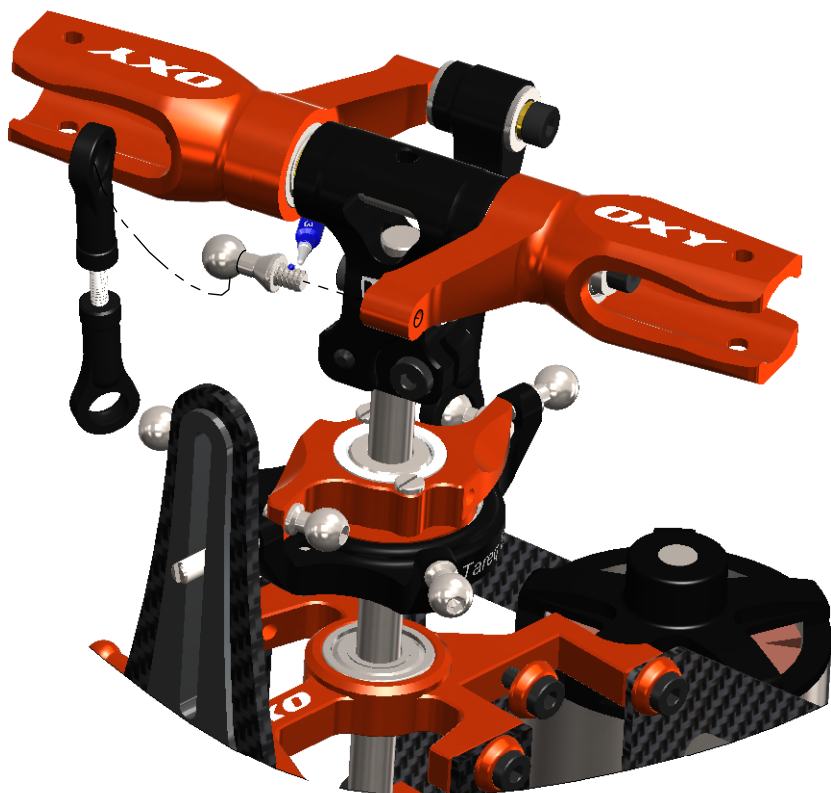
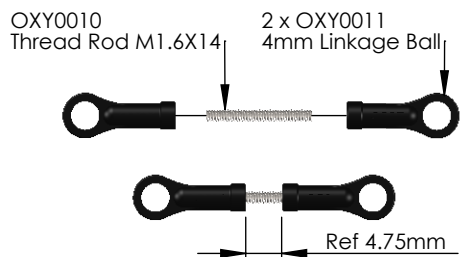

FBL Head System.

Step 1

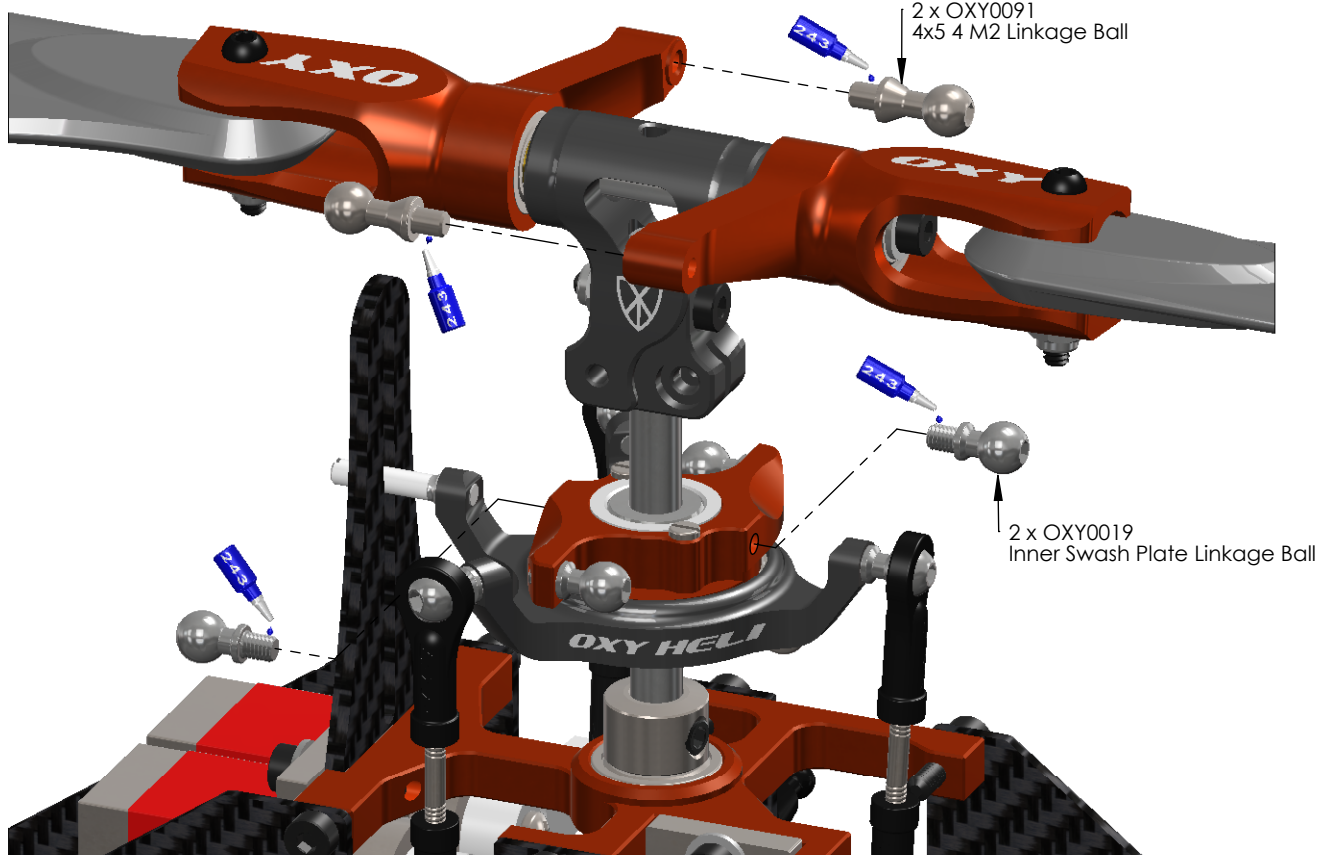

Step 2

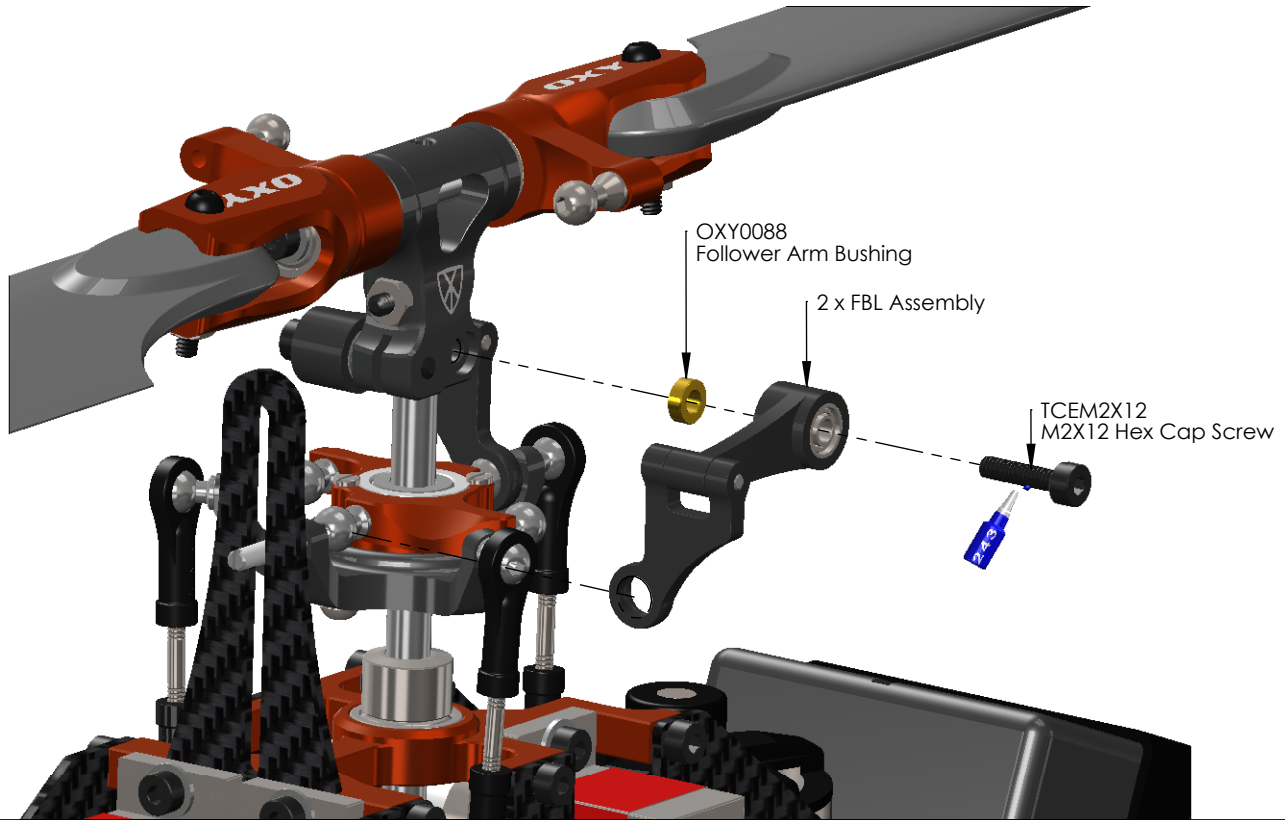

Step 3

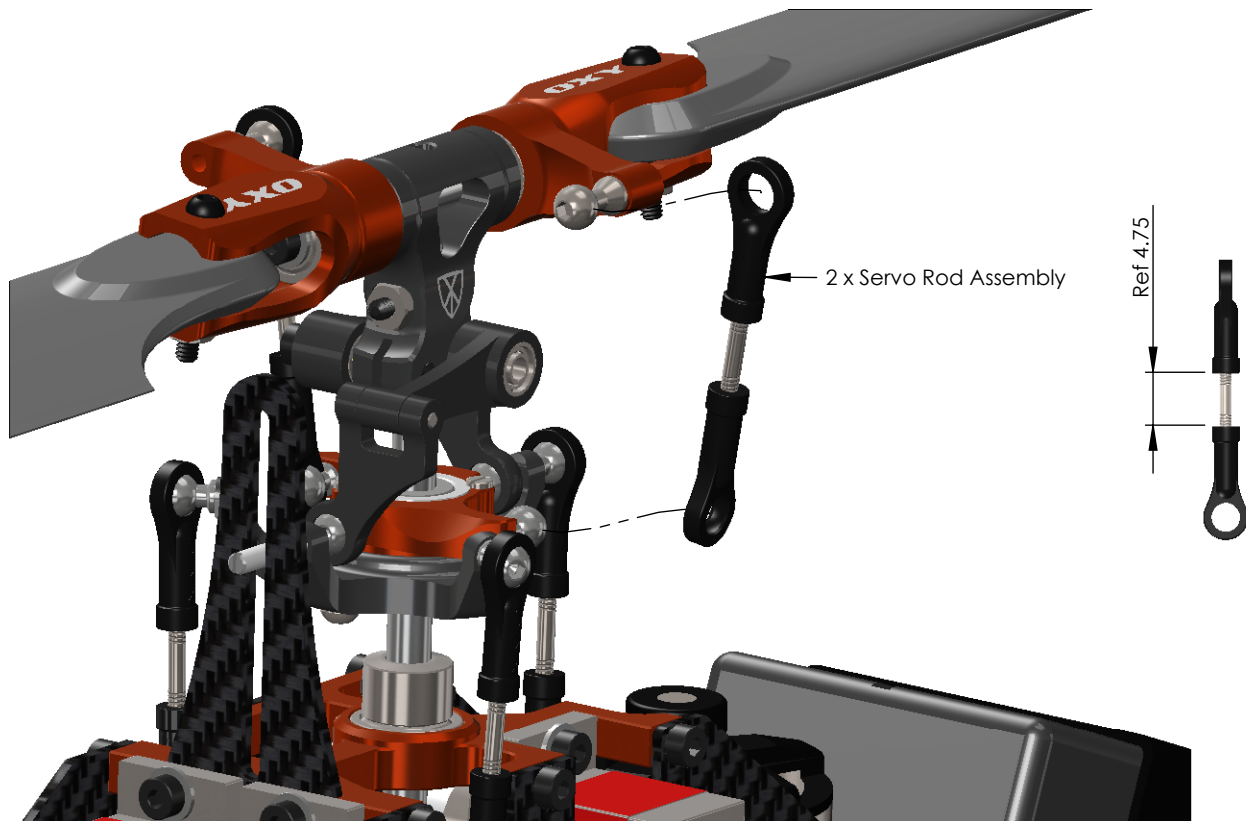

- You should now do some initial setup of your FBL unit and servos.
- We recommend you select a new model in your transmitter, and reset your FBL unit and start with a clean setup in it as well.
- After binding your transmitter to the receiver system used with the FBL unit, work your way through the FBL setup instructions to the point you plug in your servos.
- Now set your collective stick in the middle position, and position the servo arms as close to the correct positions you can on each servo see the following pages for arm orientations on the various servos.
- Next confirm the servos work in the correct direction, then return the collective stick to the center position.
- Now use your FBL unit to trim the servos so the arms are exactly horizontal (see pictures below).
- This procedure varies between units. Carefully label the position of the servos, then proceed with the installation of the servos as shown.

Front Cyclic Servo. (Box 1 / Bag 19)

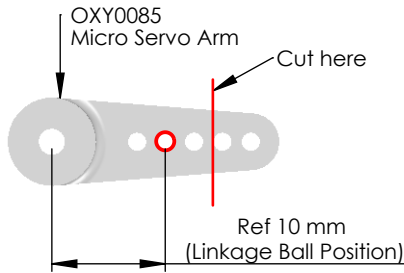

! Linkage Ball Direction: Front cyclic servo Linkage Ball, must installed as shown.

! Arm position with zero deg pitch and centered cyclic stick.

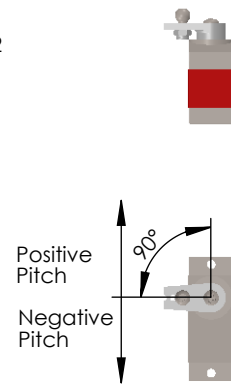
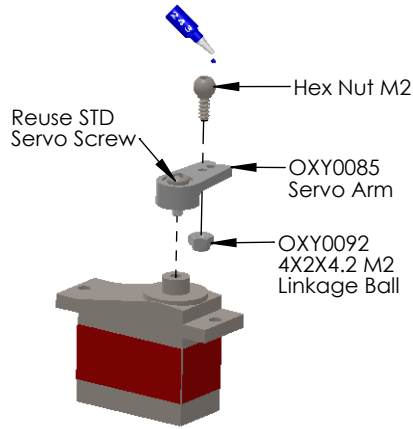

Left, Right Servos. (Box 1 / Bag 19)

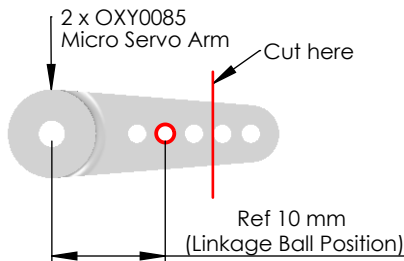

! Linkage Ball Direction: Left and Right servo Linkage Balls must be installed as shown.

! Arm position with zero deg pitch and centered cyclic stick.

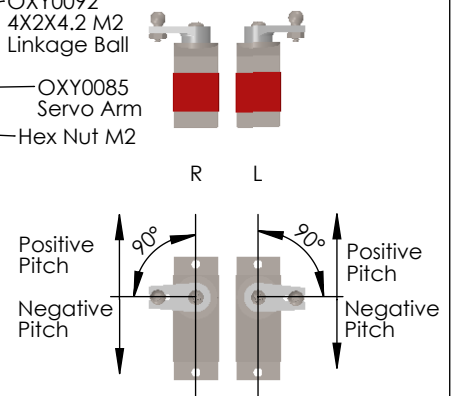
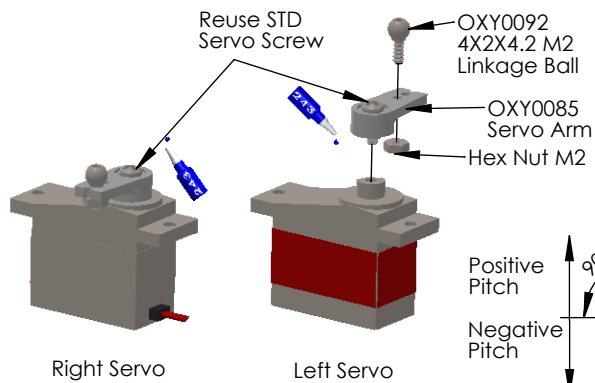

Tail Servo. (Box 1 / Bag 19)

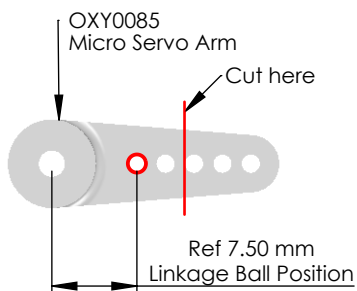

! Linkage Ball Direction: The Tail servo Linkage Ball must be installed as shown.

! Arm position with zero deg pitch and centered rudder stick.

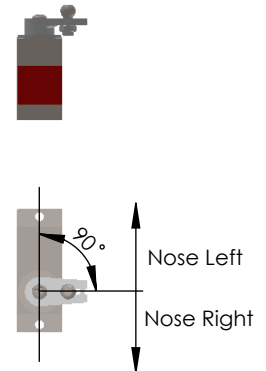
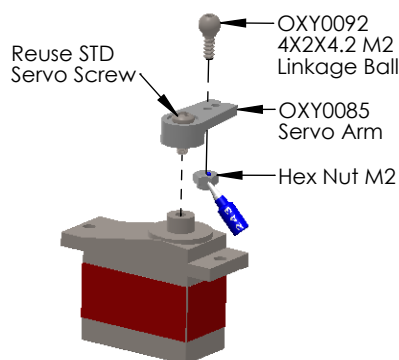

Front Cyclic Servo Assembly.

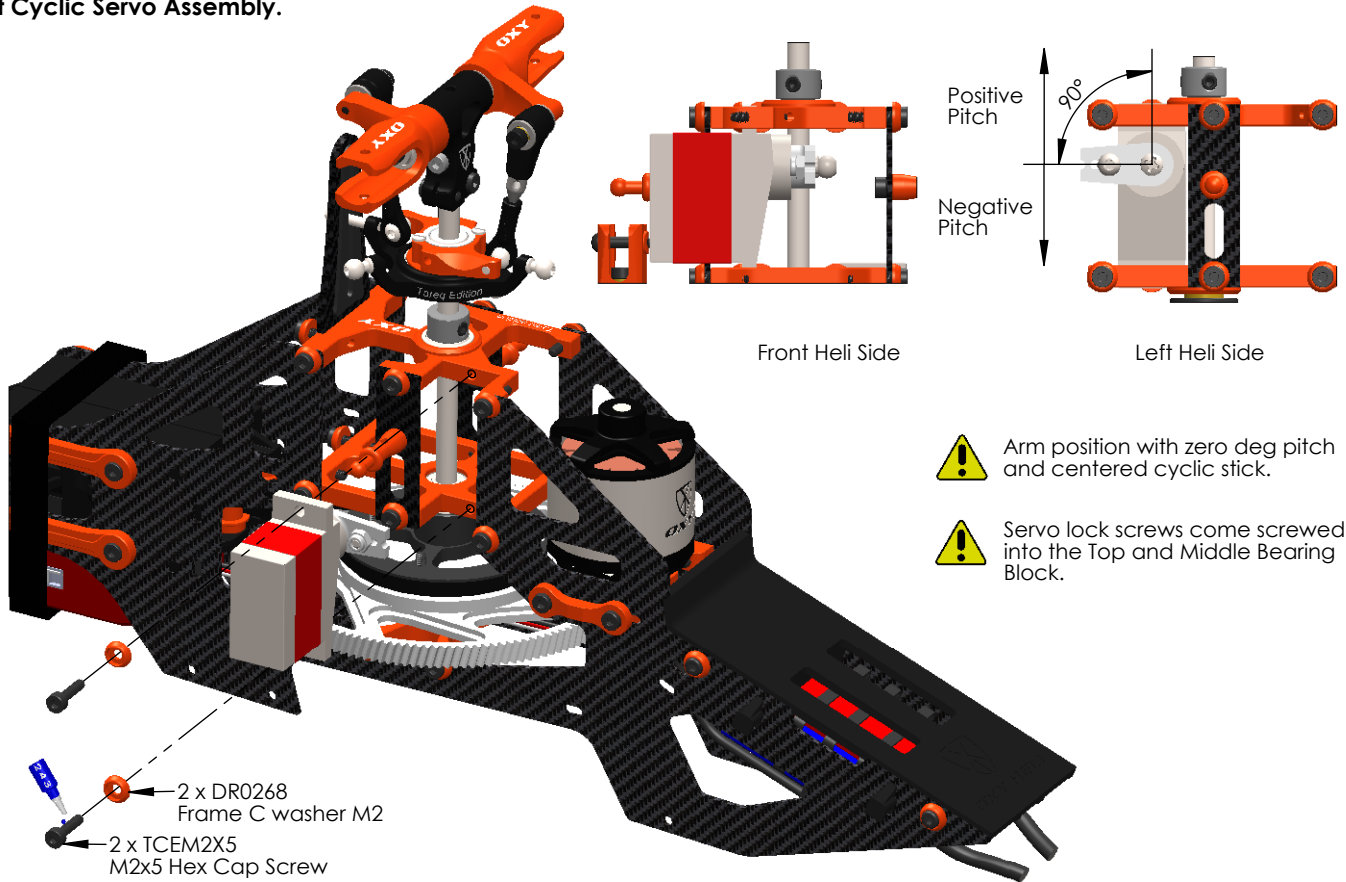

Left and Right Cyclic Servos Assembly.

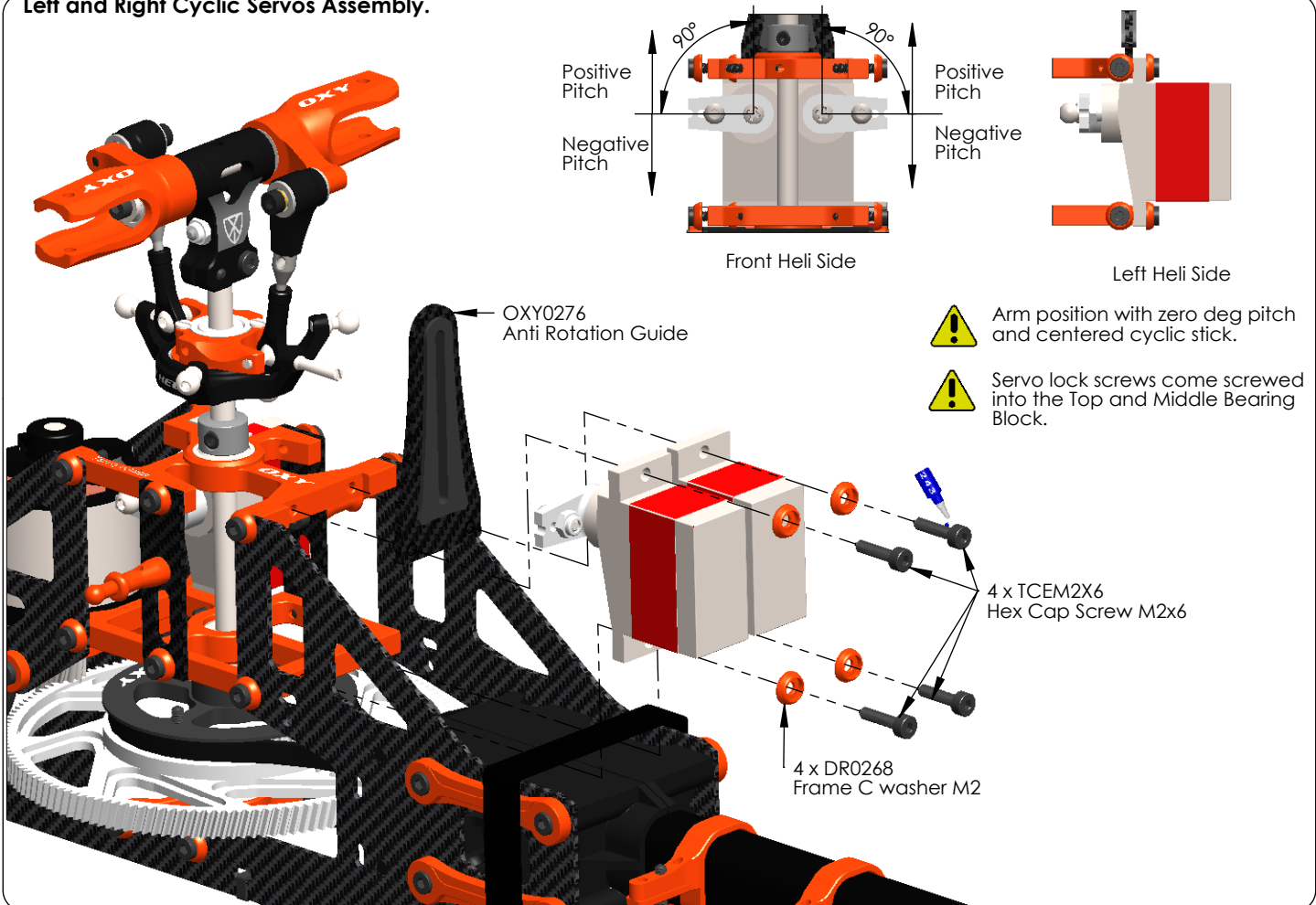

Tail Servo Assembly.

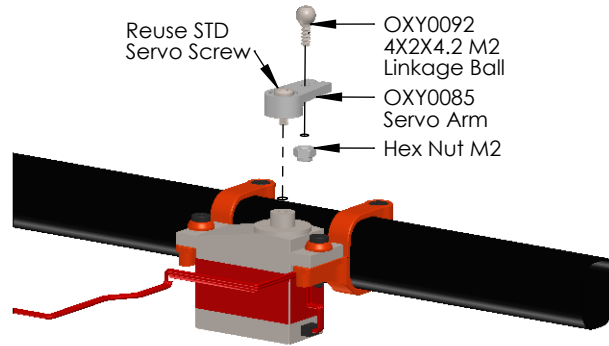
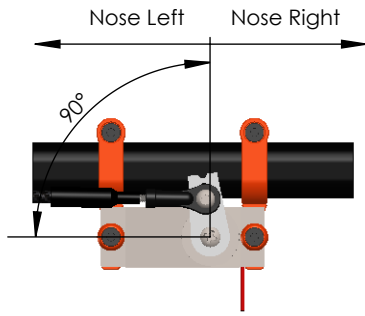

Tail Push Rod Assembly.

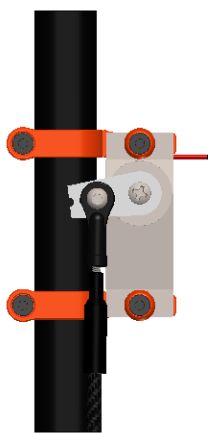
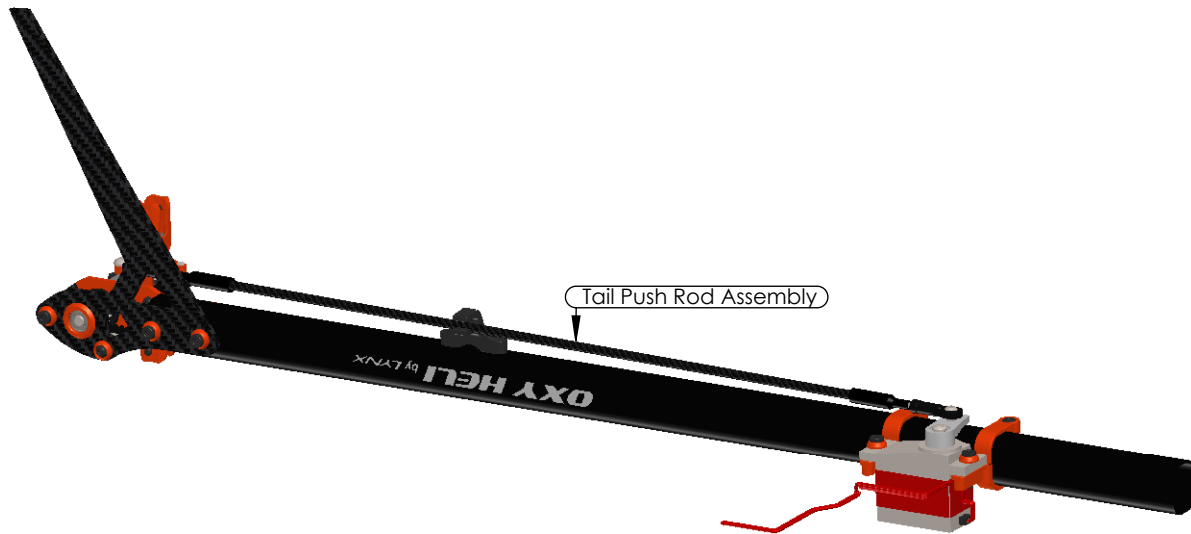

⚠ Arm position with centered Rudder stick.

Bottom Heli View

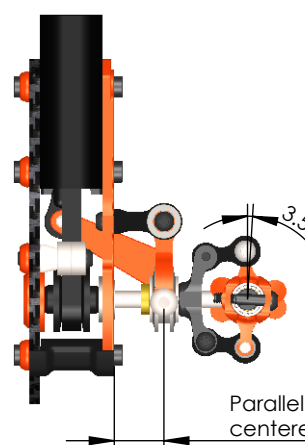

With Rudder Stick centered and the Tail Servo Arm in the center position, adjust the Tail Push Rod length until the Tail Bell Crank and Tail Case Plate are parallel as shown.



The Oxy 3 Tail System has approximately 3.5° of counter torque with the Tail Bell Crank set per instructions.

Parallel arm position with centered Rudder stick.

Top Heli View

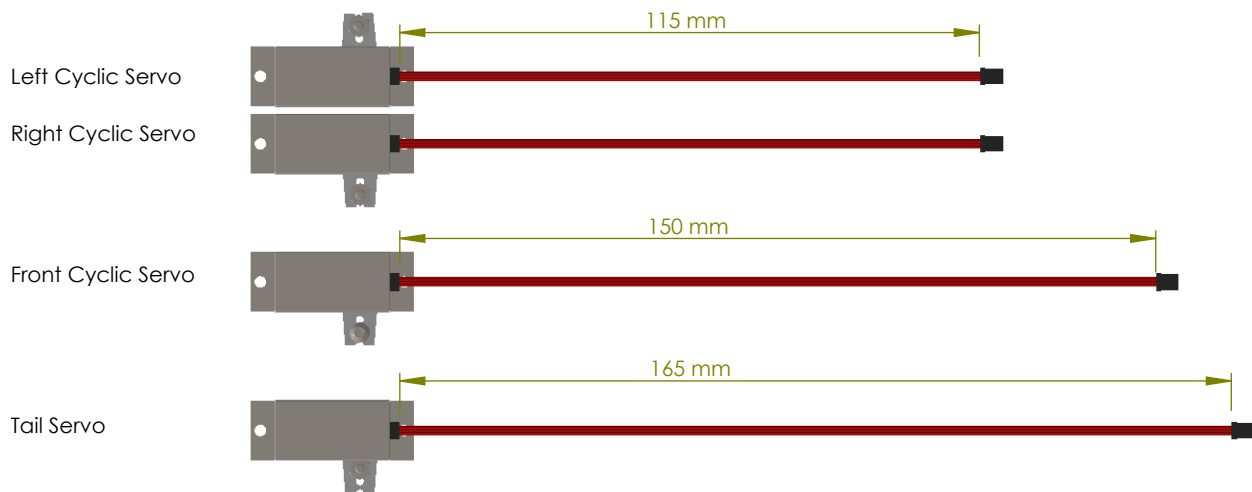
Finalize servo connection, wiring.**Suggest Servo Wiring Dimension**

⚠ Servo Wiring Length:
For a clean wiring installation, we suggest trimming the servo wires as shown. It is important to use the correct tools: Servo Terminals and Crimp Pliers. If you don't have these specific tools, it is best to leave your servo wires at their standard length and use Cable Ties to lock and secure the wires.

Electronics Wiring.

Follow our schematics suggestion for the cleanest wiring set up.

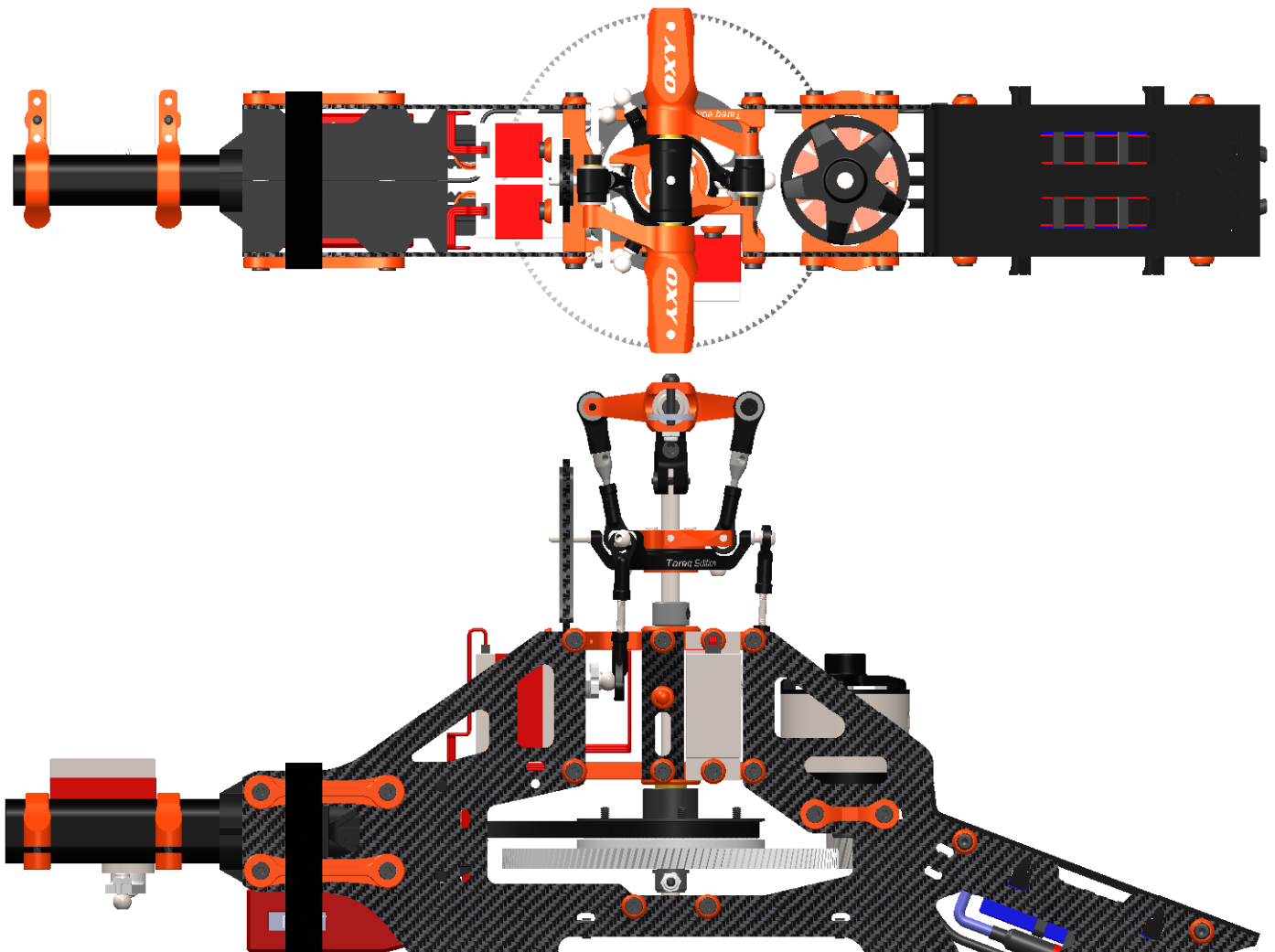

⚠ Use Cable Ties to hold and secure Servo Wires to the Main frame using our suggestions above, and the Main Frame built-in sockets. For Extra information about wiring, visit the oxyheli.com web site under Tutorials and Tips.

Servo Rod Assembled. (Box 1 / Bag 19)

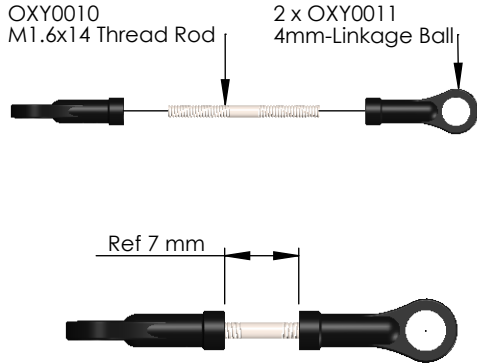

It is really important the servo rods screw onto the linkages the same amount. The Plastic ball links have a oxy logo to give you information about turn adjustment, but have a symmetrical ball socket shape and can be installed in either direction to achieve the best fine tuning.

Install Sevo rod into Swash Plate and Servo.

3 x Servo Rod Assembly



Landing Gear Assembly.



Once the servo connectors are in place and secured with cable ties, you can finalize the assembly by installing the landing gear.

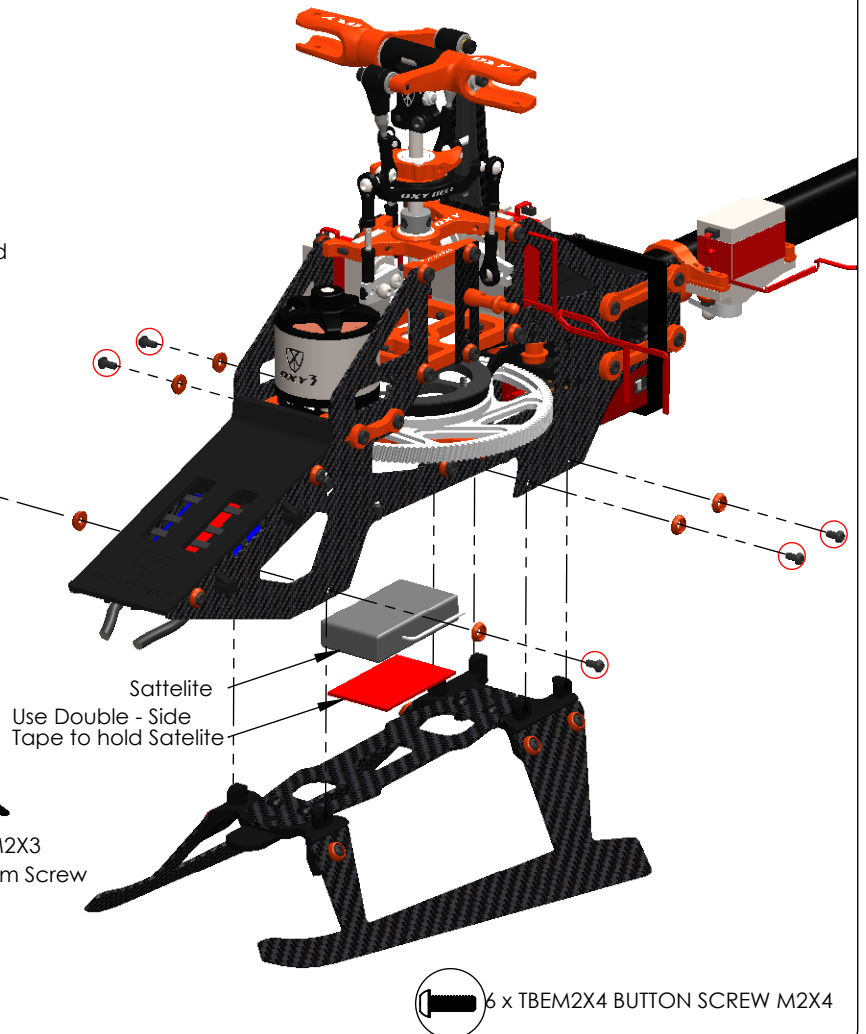
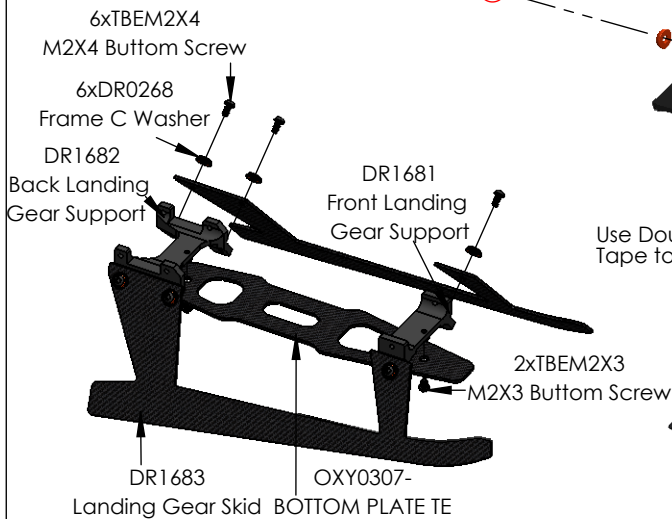

Before Flight.

Now complete the setup of your FBL system. In the Accessories Bag you will find an Oxy 3 Swash Plate Leveler. This Tool is designed to fit under the Swash Plate without disassembly any parts. This simple tool will both level the swash and give the Zero Pitch Position.
 Starting gyro gain: The Oxy 3 was designed around famous FBL Systems (IKON / Brain / mini V-Bar), and we suggest you start with the following standard set up and adjust after test flying.
 Cyclic Set Up:
 Use suggested settings for 450 Helicopters and adjust after test flights.
 See our table on page 15 for RPM and Pitch Settings. Cyclic Max pitch should be +/- 10.5 deg.
 Tail Set Up:
 Use the suggested settings for 450 Helicopters BUT start with a lower Tail Gain
 IKON / Brain = 20%
 Mini V-Bar = 250 Heli suggested gain.

Main Grip assembly.

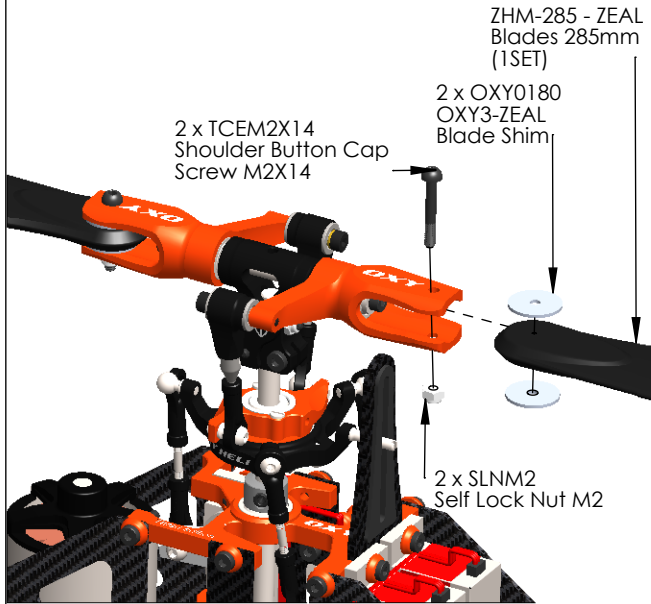

! Note: The Oxy Main Grips have a 5.5mm root cavity in order to work with any standard 245 / 255 main blade root. Use main blade shims if necessary. Shims are usually supplied with the main blades.

Tail Grip assembly.

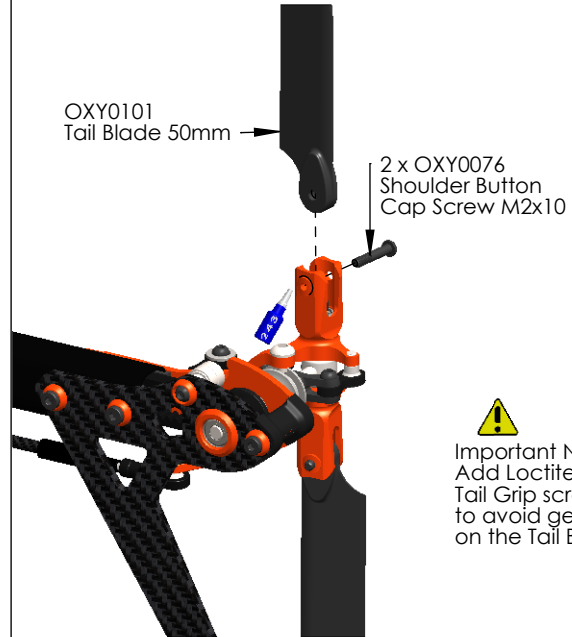

! Important Note: Add Loctite onto the Tail Grip screw thread to avoid getting Loctite on the Tail Blades.

! Oxy tail blade dimension note: In order to assure the best performance Oxy made a custom tail blade with a 3.5mm root. If you use different tail blades with a 2.5mm root you must use shims (not included).
 Information about 47 and 50mm tail blades: In the kit we include two sets of tail blades - the 47mm are designed for high head speed, the 50mm are designed for low head speed. We recommends using 47mm when head speed is higher than 4000rpm.

Battery Assembly.

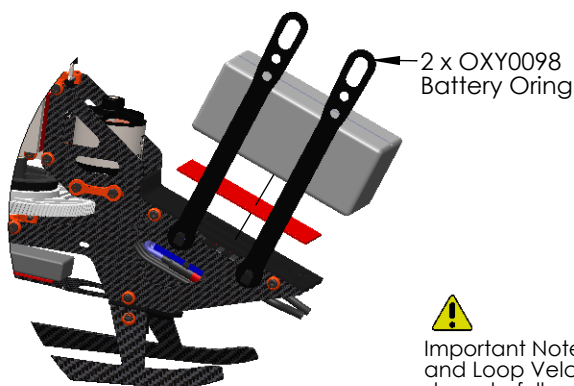

! Important Note: Use both double sided Hook and Loop Velcro and the included battery straps to fully secure the battery pack.



Step 1

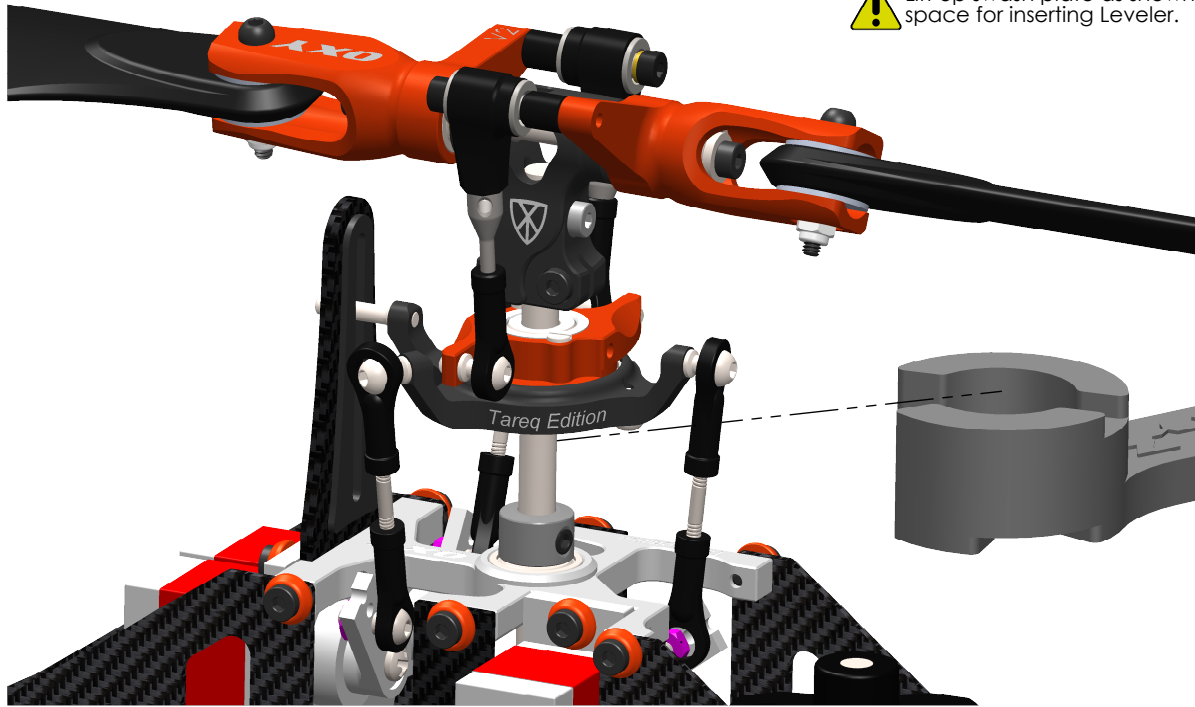

 Lift up swash plate as shown to have space for inserting Leveler.

Step 2

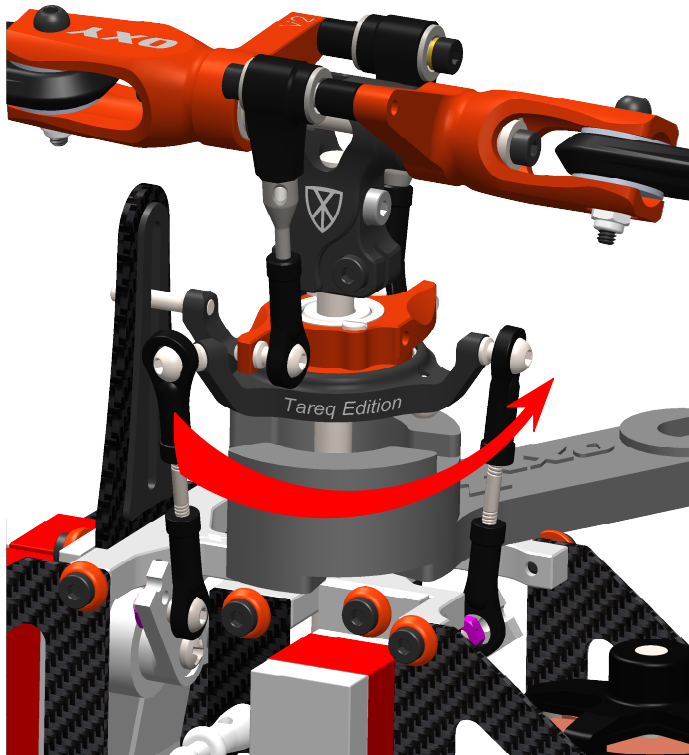

 Rotate Swash Plate Leveler as shown.

Step 3

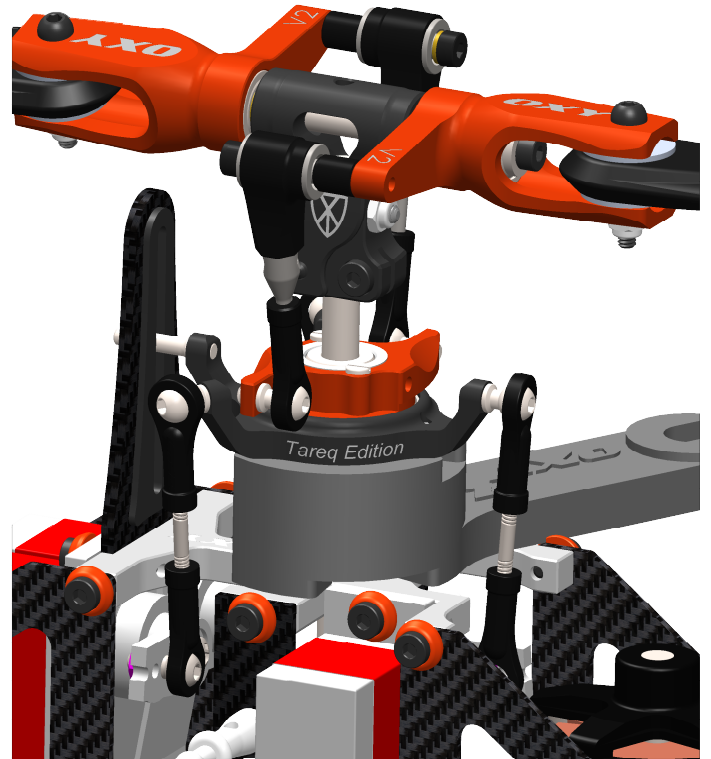

 Note: pay attention screws's position at the bottm of Swash Plate. Leveler's position as shown after rotating.

Step 4

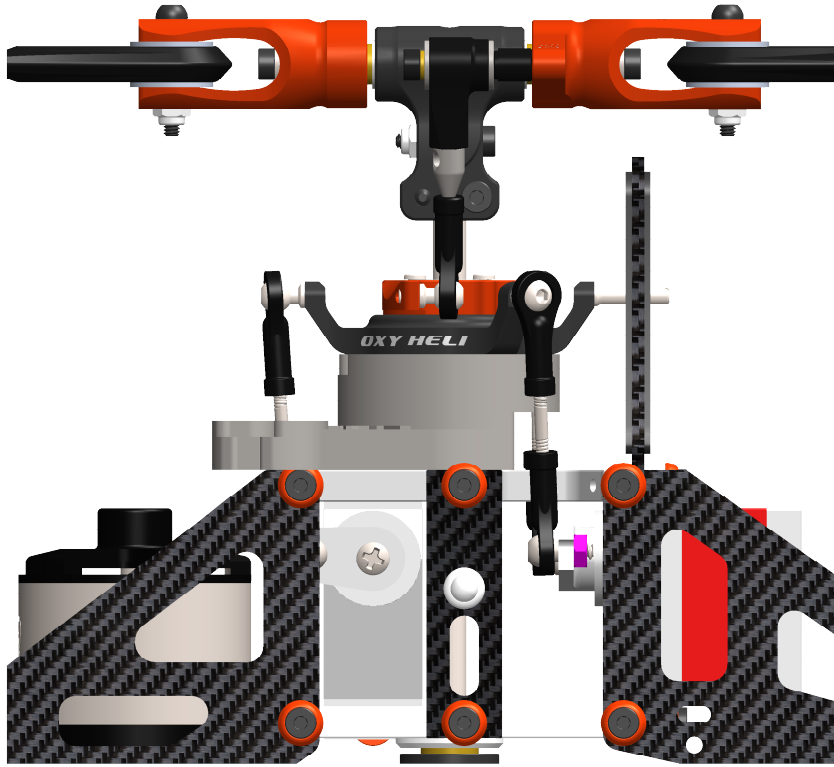

Lift Swash Plate down until Swash Plate touch Leveler as shown.

Left heli side

Step 5



After removing Leveler, the position of servo arms as shown.



Left heli side

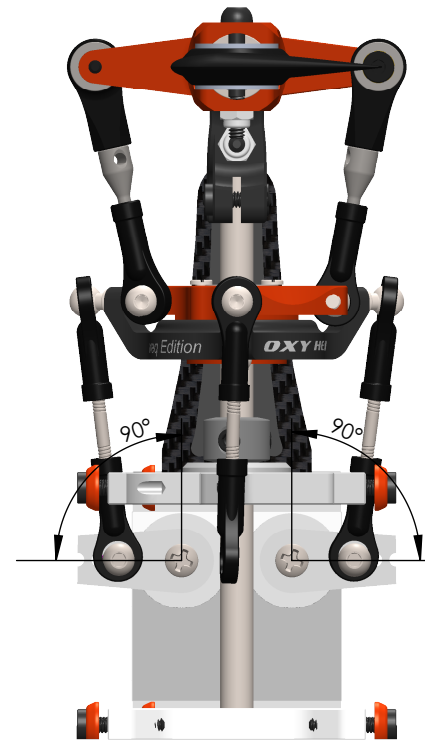

Front heli side

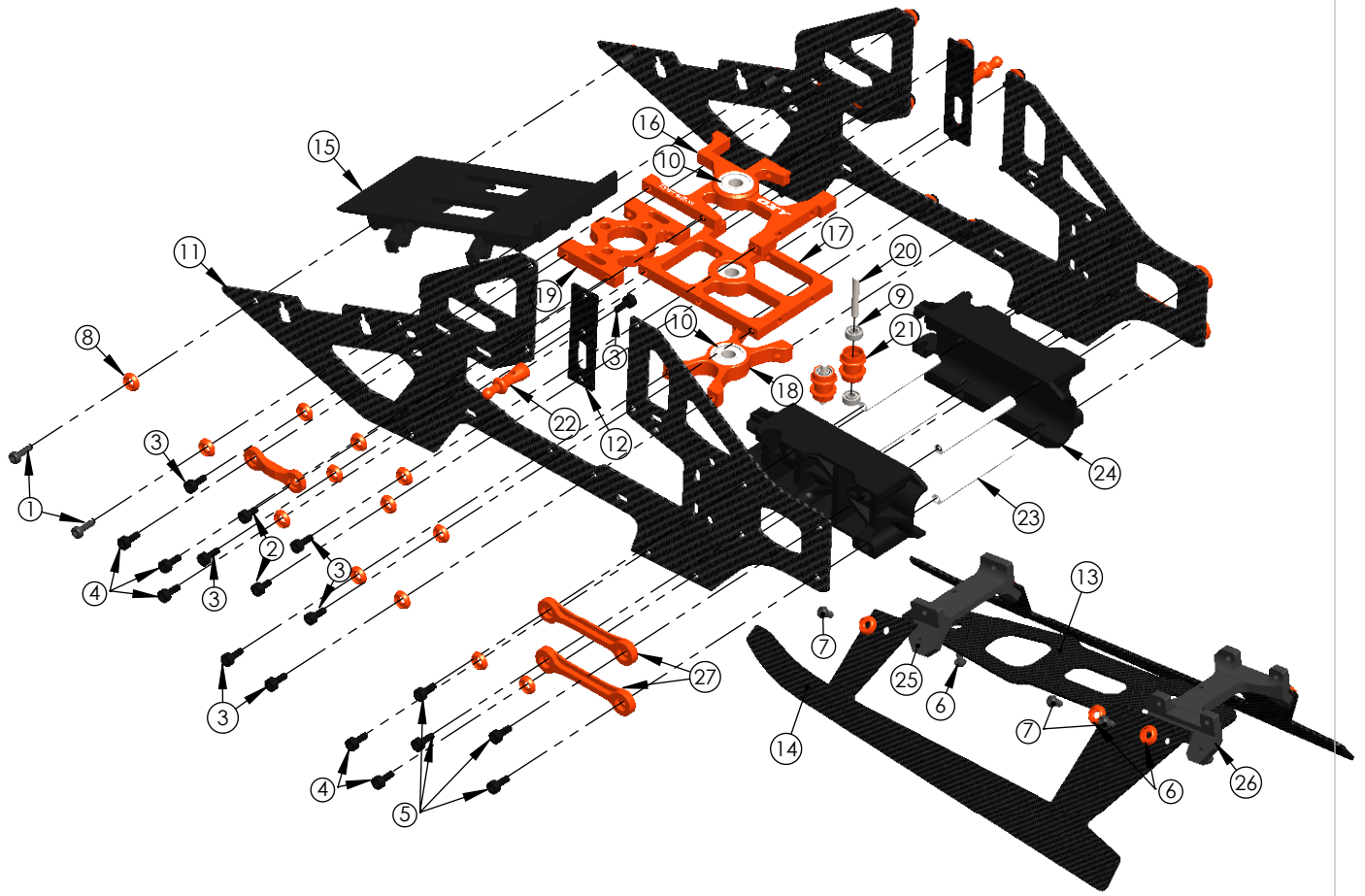

POS	CODE	NAME	SPECIFICATION	QUAN
1	TBES2X6	M2x6 Self Tapping Screw	Alloy Steel	4
2	TCEM2X4	M2x4 Hex Cap Screw	Alloy Steel	4
3	TCEM2X5	M2x5 Hex Cap Screw	Alloy Steel	14
4	TCEM2x6	M2x6 Hex Cap Screw	Alloy Steel	10
5	TCEM2X8	M2x8 Hex Cap Screw	Alloy Steel	8
6	TBEM2.5x5	M2.5x5 Button Hex Cap Screw	Alloy Steel	4
7	TBEM2x4	M2x4 Button Hex Cap Screw	Alloy Steel	6
8	DR0268	Frame C washer M2	60661-T6	32
9	MR52-W2	Radial Bearing 2x5x2	STD	4
10	MR104ZZ-W4	Radial Bearing 4x10x4	STD	3
11	OXY0030	Main Frame	CF 1mm	2
12	OXY0033	Break Way Canopy Mount	CF 1mm	2
13	OXY0307	BOTTOM PLATE TE	CF 1mm	1
14	OXY0149	Landing Gear skid	CF 1mm	2
15	OXY0035	OXY0035	POM	1
16	OXY0026	Upper Main Shaft Bearing Block	6061-T6	1
17	OXY0027	Middle Main Shaft Bearing Block	6061-T6	1
18	OXY0028	Lower Main Shaft Bearing Block	6061-T6	1
19	OXY0029	Motor Mount	6061-T6	1
20	OXY0023	2x13.5 Pin	SST	2
21	OXY0024	Pulley Guide	POM	2
22	OXY0025	Canopy Mount	POM	2
23	OXY0022	Lock Rod	6061-T6	4
24	OXY0002	Boom Clamp	POM	2
25	DR1681	front landing gear support Back	60661-T6	1
26	DR1682	Landing Gear Support	6061-T6	1
27	DR1806	Aluminum Stiffener	6061-T6	4

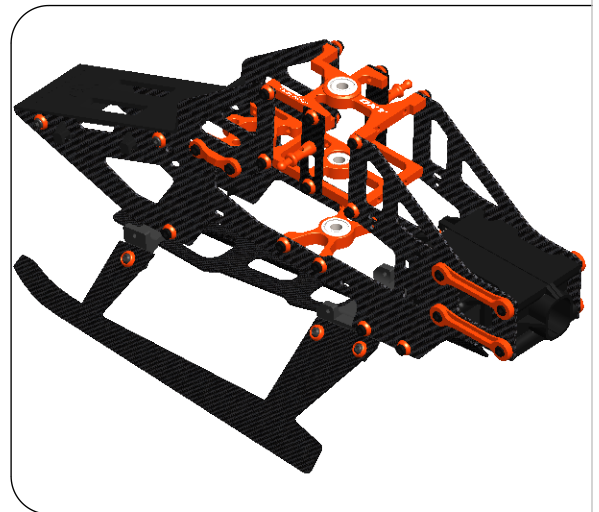

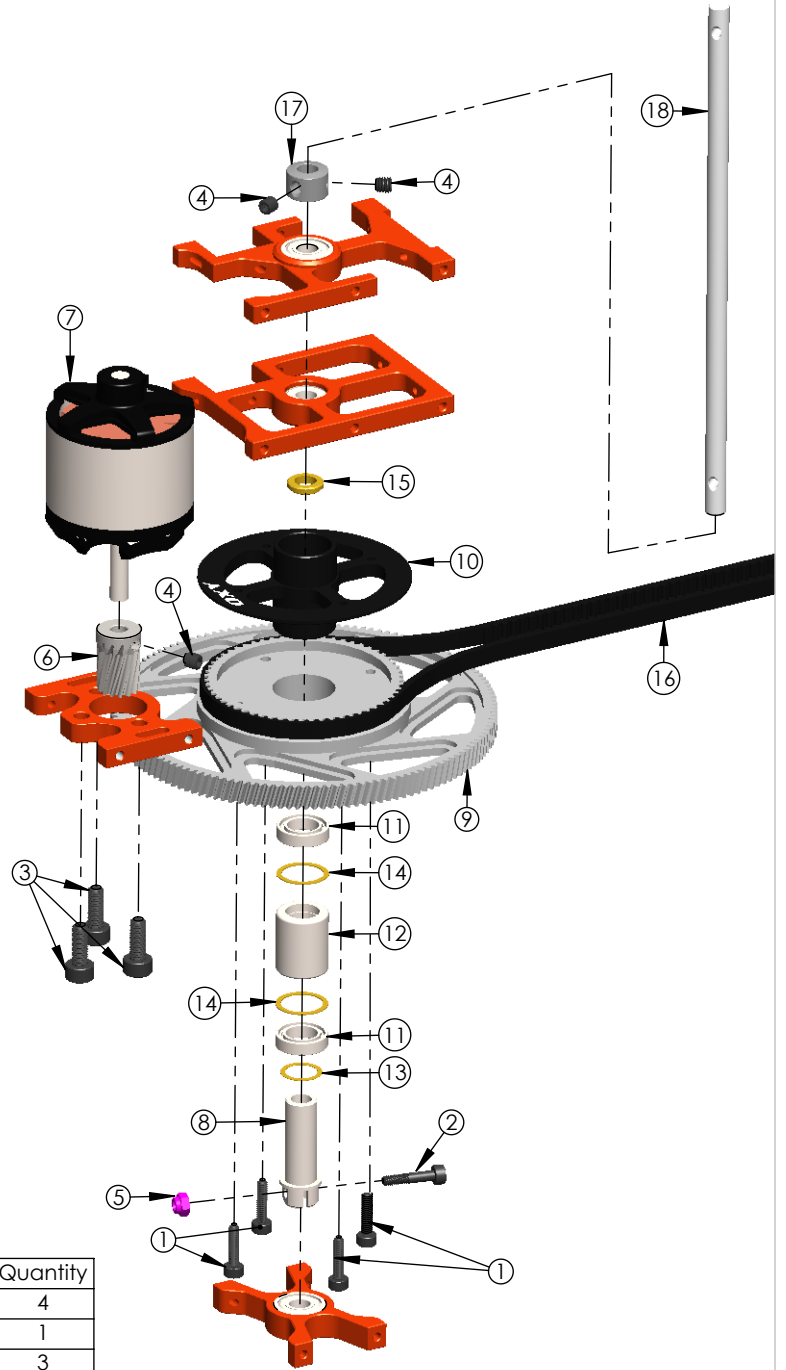
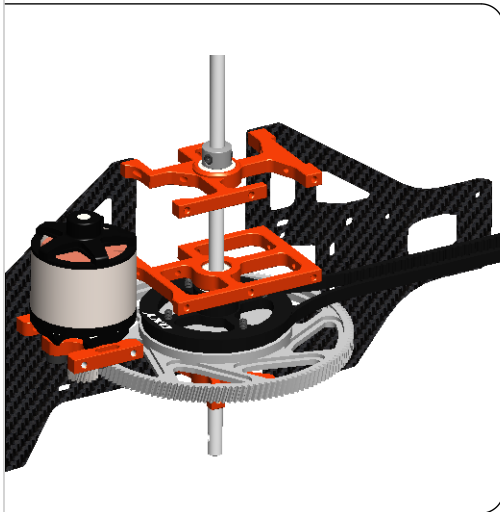

POS	COD	Name	Specification	Quantity
1	TCEM2X6	M2x6 Hex Cap Screw	Alloy Steel	4
2	OXY0076	M2x10 Hex Cap Screw	Alloy Steel	1
3	TCEM3X8	M3x8 Hex Cap Screw	Alloy Steel	3
4	SCM3X3	M3X3 Set Screw	Alloy Steel	3
5	SLNM2	Self Lock Nut M2	Alloy Steel	1
6	OXY0104	Pinion 10t- M0.5 - 3.17 Motor Shaft	Steel	1
	OXY0094	Pinion 11t- M0.5 - 3.17 Motor Shaft	Steel	1
	OXY0095	Pinion 12t- M0.5 - 3.17 Motor Shaft	Steel	1
	OXY0096	Pinion 13t- M0.5 - 3.17 Motor Shaft	Steel	1
	OXY0042	Pinion 14t- M0.5 - 3.17 Motor Shaft	Steel	1
	OXY0086	Pinion 15t- M0.5 - 3.17 Motor Shaft	Steel	1
7		LX8005 - EOX Motor 2214-3S-4100KV		1
8	OXY0041	One Way Sleeve	C40	1
9	OXY0001	Main Gear	PA66	1
10	OXY0037	Main Pulley Flange	6061-T6	1
11	MR104ZZ-W4	Radial Bearing 6X10X2.5	STD	2
12	HF0612	One Way Bearing 6X10X12	STD	1
13	OXY0040	Shim Washer 6.1X8X0.1	Brass	1
14	OXY0039	Washer 8x10x0.2	Brass	2
15	OXY0038	Auto Rotation Spacer	Brass	1
16		Timing Belt - B424MXL - 3mm Thickness		1
17	OXY0004	Main Shaft Lock Ring	SUS 304	1
18	OXY0003	Main Shaft	Hard Steel	1

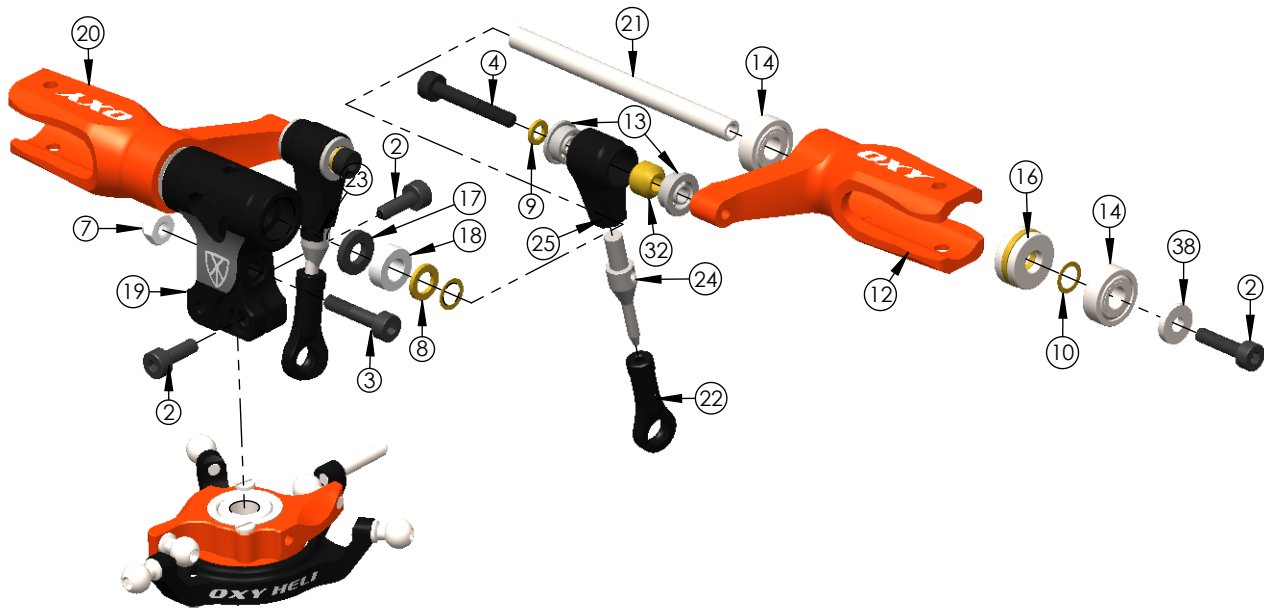

POS	COD	Name	Specification	Quantity
1	TCEM2X5	M2x5 Hex Cap Screw	Alloy Steel	4
2	TCEM2X6	M2x6 Hex Cap Screw	Alloy Steel	6
3	OXY0076	M2X10 Shoulder Hex Cap Screw	Alloy Steel	1
4	TCEM2X14	M2x14 Hex Cap Screw	Alloy Steel	2
5	OXY0020	M1.2x2 Special Screw	SST	2
6	OXY0111	M1.6X3 Button Head Screw	Alloy Steel	2
7	SLNM2	Self Lock Nut M2	Alloy Steel	1
8	OXY0137	3.1x5x0.6 Washer	Brass	2
9	OXY0055	2x3.5x0.2 Washer	Brass	2
10	Oxy0054	3x4x0.1 Washer	Brass	2
11	WM2	WM2 Washer M2	SST	6
12	OXY0180	ZEAL Blade Shim	6061-T6	4
13	MF682ZZ	Flange Bearing 2X5X2.3	STD	4
14	MR83_ZZ/W2.5	Radial Bearing 3X8X2.5	STD	4
15	MR6701_ZZ	Radial Bearing 12x18 H4	STD	1
16	F3-8G_X	thrust bearing 3x8 h3.5	STD	2
17	OXY0110	Rubber Dampener	Rubber	2
18	OXY0079	Dampener Bushing	POM	2
19	OXY0005	Center Hub	6061-T6	1
20	OXY0008	Main Grip	6061-T6	2
21	OXY0007	Spindle Shaft	Hard Steel	1
22	OXY0011	4mm-linkage ball	POM	8
23	OXY0010	Thread Rod M1.6 X 14	SST	2
24	DR0604	300X - DFC Rod Short	SST	2
25	OXY0009	Aluminum DFC Arm	6061-T6	2
26	OXY0014	Lower Swash Plate	6061-T6	1
27	DR1689	Upper Swash Plate	6061-T6	1
28	OXY0017	Center Ball	SST	1
29	OXY0016	Ball Holder	POM	1
30	OXY0018	Antirotation Pin	Steel	1
31	OXY0019	Swash Plate Ball 2x3.7x4.4	Steel	5
32	OXY0012	Bushing	Brass	2
33	OXY0010	Servo Rod M1.6x14	Steel	3
34	OXY0276	Anti-Rotation Guide	CF 1.5 mm	1
35	OXY0085	Servo Arm	POM	3
36	OXY0092	4X2X4.2 M2 Linkage Ball	SST	3
37		Hex Nut M2	Alloy Steel	3
38	OXY0081	2.1X5.5X1 Washer	Brass	2

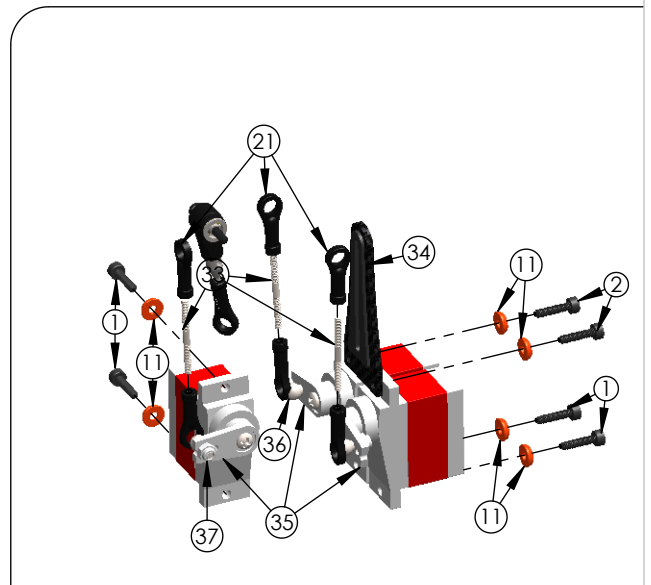

Swash Plate Set

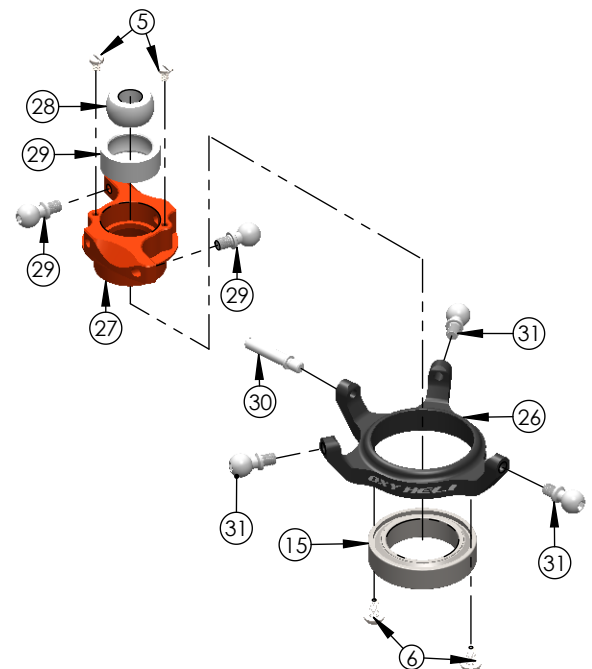

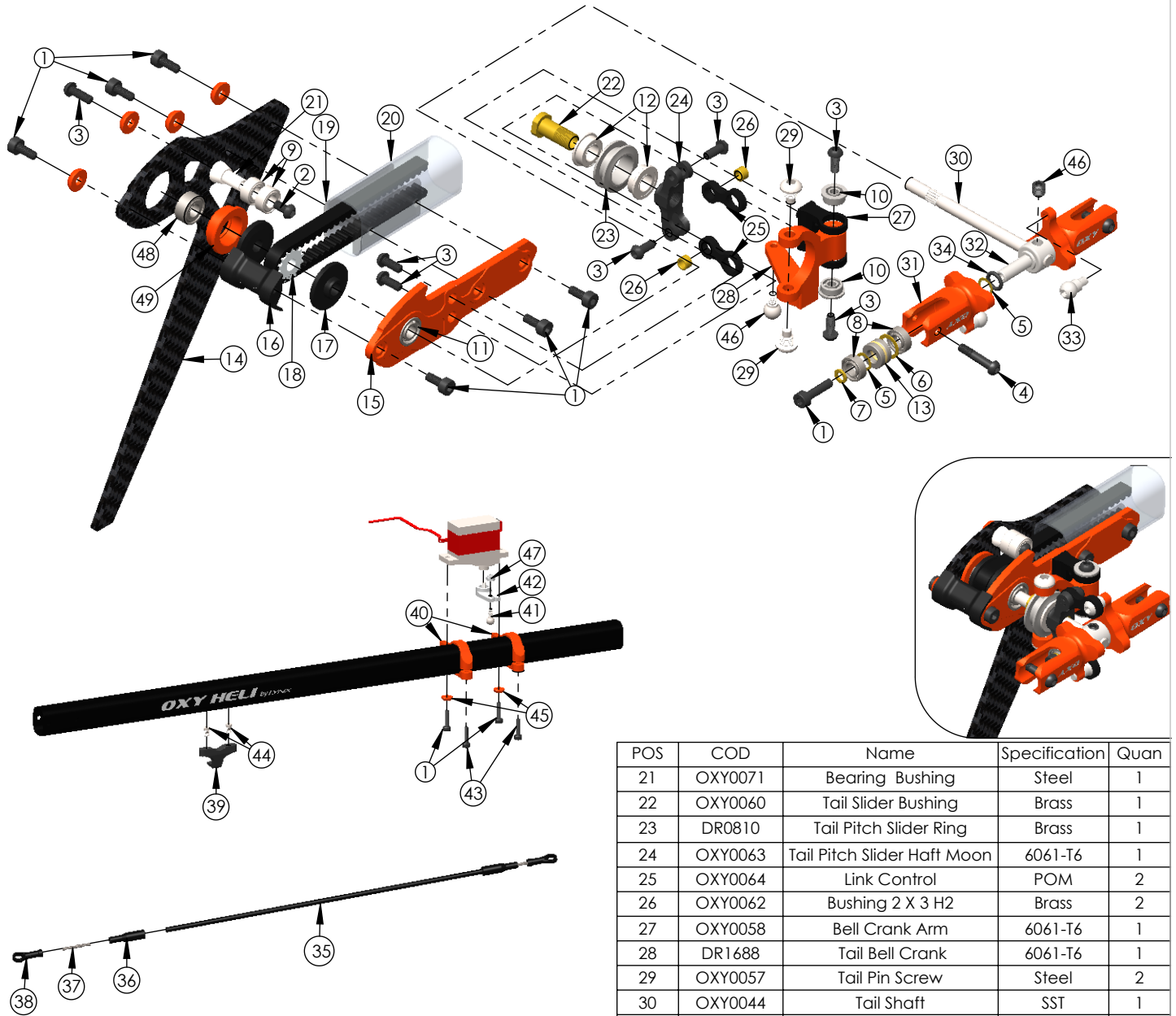

POS	COD	Name	Specification	Quan
1	TCEM2x5	M2x5 Hex Cap Screw	Alloy Steel	8
2	TBEM2x4	M2x4 Button Screw	Alloy Steel	1
3	TBEM2x5	M2x5 Button Screw	Alloy Steel	7
4	OXY0078	M2X10 Shoulder Buttom Screw	Alloy Steel	2
5	OXY0054	3x4x0.1 Shim Washer	Brass	4
6	OXY0053	4.2X6X0.2 Washer	Brass	2
7	OXY0055	2X3.5 W 0.5 Shim Washer	SST	2
8	MR63-W2	Radial Bearing 3X6X2	STD	4
9	MR63_ZZC	Radial Bearing 3X6X2.5	STD	2
10	MF682ZZ	Flange_Bearings_2x5x2.3	STD	2
11	MF73_ZZ/W3	Flange_Bearings_3x7x3	STD	2
12	MF74-ZZ	Flange_Bearings_4x7x2.5	STD	2
13	F3-6G-W3.5	Thrust Bearing 3x6 W3.5	STD	2
14	DR1715	Vertical Fin Block	CF 2mm	1
15	DR1717	Tail Case Bearing Block	6061-T6	1
16	OXY0072	Tail Case Cover	POM	1
17	OXY0046	Flange Tail Pulley	POM	2
18	OXY0045	15T Tail Pulley	6061-T6	1
19	OXY0073	Tail Case Center	6061-T6	1
20	DR1718	Square Boom 11X14X0.5X318	6061-T6	1

POS	COD	Name	Specification	Quan
21	OXY0071	Bearing Bushing	Steel	1
22	OXY0060	Tail Slider Bushing	Brass	1
23	DR0810	Tail Pitch Slider Ring	Brass	1
24	OXY0063	Tail Pitch Slider Haft Moon	6061-T6	1
25	OXY0064	Link Control	POM	2
26	OXY0062	Bushing 2 X 3 H2	Brass	2
27	OXY0058	Bell Crank Arm	6061-T6	1
28	DR1688	Tail Bell Crank	6061-T6	1
29	OXY0057	Tail Pin Screw	Steel	2
30	OXY0044	Tail Shaft	SST	1
31	OXY0051	Tail Grip	6061-T6	2
32	OXY0049	Tail Hub	SST 304	1
33	OXY0050	Linkage Ball 4 X 3 M2	SST	2
34	OR-2X1	O-RING ID 2 - W 1	Rubber	2
35	DR1719	CF Rod 214 mm	CF	1
36	DR1076	Tail Push Rod Terminal	POM	1
37	DR1708	Thread Rod M1.6X10	SST	2
38	OXY0011	4 mm Linkage Ball	POM	2
39	OXY0067	Guide Push Rod	POM	1
40	OXY0084	Tail Servo Mount	6061-T6	2
41	OXY0092	4X2X4.2 M2 Linkage Ball	SST	1
42	OXY0085	Servo Arm	POM	1
43	TCEM2X6	Hex Cap Screw M2x6	SST	4
44	OXY0068	Pin Screw	SST	2
45	DR0268	Frame C washer M2	6061-T6	6
46	SCM3X3	Set Screw M3x3	SST	1
47		Hex Nut M2	Alloy Steel	1
48	MR73_ZZ	Radial bearing 3x7x3	STD	1
49	DR1716	Tail Case - Bearing Bushing	6061-T6	1

**SP-OXY3-111 - OXY3 - Center Hub**

- 1 x Center Hub
- 1 x M2X10 Shoulder Hex Cap Screw
- 1 x M2-Lock Nut
- 2 x M2x6 Hex cup screw

SP-OXY3-112 - OXY3 - Ultra Main Grip, Set

- 2 x Main Grip
- 4 x MR83_ZZ-3x8x2.5 Radial Bearing
- 2 x 3x8x3.5 Thrust Bearing
- 2 x 3x4x0.1 Shim Washer
- 2 x M2X14 Shoulder Bottom Cap Screw
- 2 x M2-Lock Nut

SP-113 - OXY3 - Aluminum DFC/ Hybrid Arm

- 2 x DFC Arm
- 4 x 2x5x2.3 Flange Bearing
- 2 x DFC Rod Short
- 4 x 4mm Linkage Ball
- 2 x DFC Arm Spacer
- 2 x 2x3.5x0.5 Shim Washer
- 2 x M2X14 Shoulder Hex Cap Screw
- 2 x Thread Rod M1.6 x 14
- 1 x 4x5.4_link_ball

SP-OXY3-114 - OXY3 - Swashplate

- 1 x Lower Swash Plate
- 1 x Upper Swash Plate
- 1 x Radial Bearing 12x18 H4
- 1 x Ball Holder
- 1 x Center Ball
- 1 x 2x11.5 Antirotation Pin
- 7 x Inner Swash Plate Linkage Ball
- 2 x M1.6X3 Bottom Screw
- 2 x M1.2x2 Special Screw

**SP-OXY3-003 - OXY3 -
Carbon Steel Spindle Shaft, 2PC**



2 X Hardened Steel Spindle Shaft
2 X 2.1X5.5X1 Washer
2 X M2x6 Hex cup screw

**SP-OXY3-004 -
OXY3 - Dampeners, 2 Set**



4 x Damper Bushing
4 x Rubber Dampener
4 x 3x4x0.1 Shim Washer
2 x 3.1X5X0.6 Washer

**SP-OXY3-066 - OXY3 -
Main Grip Service Bag**



4 x MR83_ZZ-3x8x2.5 radial bearing
2 x 3x8x3.5 Thrust Bearing
2 x 3x4x0.1 SHIM WASHER
2 x M2X14 SHOULDER BOTTOM CAP SCREW
2 x M2-Lock Nut

**SP-OXY3-148-
OXY3-DFC / Hybrid Arm Spare Set**



2 x DFC Rod
2 x M2X14 Hex Cap Screw
4 x 4mm Linkage Ball
2 x 2X3.5X0.5 Washer
1 x Threaded Rod M1.6 X 14
1 x 4x5_4_ M2 Linkage Ball

**SP-OXY3-009 - OXY3 -
Swashplate - Service Bag**



1 x Ball Holder
1 x Center Ball
1 x 2X11.5 Anti Rotation Pin
7 x Inner Swash Plate Linkage Ball
2 x M1.6X3 Button Screw
2x M1.2x2 Special Screw

**SP-OXY3-085 -
OXY3- Blade Holder**



1 x Blade Holder

**ZHM-NRG285C - ZEAL Carbon Fiber
Main Blades 285mm Energy (Neon Orange)**



1 x ZHM-NRG285C - ZEAL Carbon Fiber
Main Blades 285mm Energy (Neon Orange)

**SP-OXY3-115 - OXY3 - Upper Main Shaft Bearing Block**

1 x Upper Main Shaft Bearing Block
 1 x Radial Bearing 4x10 W4
 5 x M2x5 Hex Cup Screw
 2 x M2x6 Hex Cup Screw
 2 x M2x4 Hex Cup Screw

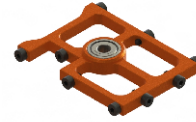
SP-OXY3-116 - OXY3 - Middle Main Shaft Bearing Block

1 x Middle Main Shaft Bearing Block
 1 x Radial Bearing 4x10 W4
 7 x Hex Cup Screw M2x5
 2 x M2x4 Hex Cup Screw

SP-OXY3-117 - OXY3 - Lower Main Shaft Bearing Block

1 x Lower Main Shaft Bearing Block
 1 x Radial Bearing 4x10 W4
 4 x Hex Cup Screw M2x5

SP-OXY3-118 - OXY3 - Motor Mount

1 x Motor Mount
 2 x OXY3 Motor Mount Stiffener
 4 x M2x6 Hex Cup Screw
 3 x M3x8 Hex Cup Screw

SP-OXY3-119 - OXY3 - Plastic Canopy Mount, 2 Set

2 x Canopy Mount
 2 x M2x4 Hex Cup Screw Self Tapping

SP-OXY3-120 - OXY3 - Main Gear

1 x Main Gear
 4 x M2x6 Hex Cap Screw

SP-OXY3-121 - OXY3 - Boom Clamp Stiffener

4 x Aluminum Stiffener

SP-OXY3-122 - OXY3 - Aluminum Belt Pulley Guide, Set

2 x 2X13.5 Pin
 2 x Pulley Guide
 4 x 2X5X2 Radial Bearing

SP-OXY3-150 - OXY3 TE - Aluminum Landing Gear V2

1 x Front Landing Gear Support
 1 x Back Landing Gear Support
 2 x Landing Gear Skid
 12 x M2x4 Bottom Screw
 2 x M2x3 Bottom Screw
 1 x Sticker of Landing Gear Skid Orange
 1 x Sticker of Landing Gear Skid Yellow
 1 x Sticker of Landing Gear Skid White
 1 x Sticker of Landing Gear Skid Green

**SP-OXY3-132 - OXY3 - Landing Gear Skid Spare Part**

2 x Landing Gear Skid
 6 x M2x4 Bottom Screw
 1 x Sticker of Landing Gear Skid Orange
 1 x Sticker of Landing Gear Skid Yellow
 1 x Sticker of Landing Gear Skid White

SP-OXY3-135-OXY3 FULL CARBON CANOPY TAREQ KIT #1



1 FULL CARBON CANOPY

SP-OXY3-104 - OXY3 - Carbon-Copolymer Anti Rotation Guide



1x ANTI-ROTATION GUIDE

SP-OXY3-138-OXY3 Motor Mount Stiffener Set



1 x OXY3 MOTOR MOUNT STIFFENER

SP-OXY3-015 - OXY3 - Battery Oring , 4PC



4 x BATTERY ORING

SP-OXY3-016 - OXY3 - Battery Tray Set

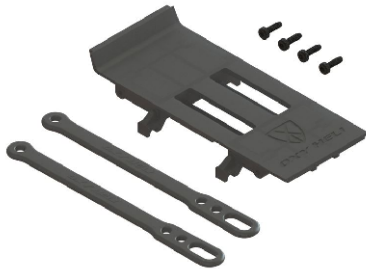

1 x BATTERY TRAY
2 x BATTERY ORING
4 x M2x6 SELF TAPPING SCREW

SP-OXY3-017 - OXY3 - One Way Hub Assembly



1 x MAIN GEAR HUB
1 x 6X10X12-ONE WAY BEARING
2 x 6X10X2.5 RADIAL BEARING
2x 8x10x0.2 SHIM
4 x M2X6 HEX CAP SCREW

SP-OXY3-018 - OXY3 - One Way Sleeve Set



2x 6X8X0.1 SHIM
1 x ONE WAY SLEEVE
1 x AUTO ROTATION SPACER
1 x M2-LOCK NUT
1 x M2X10 HEX CAP SCREW

SP-OXY3-020 - OXY3 - Boom Mount, Set

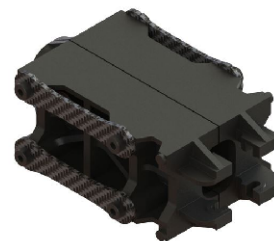

2 x BOOM CLAMP
4 x LOCK ROD
8 x M2X8 HEX CAP SCREW
4 x STIFFENER

**SP-OXY3-021 - OXY3 -
Boom Mount Lock Rod, Set**



4 x LOCK ROD
4 x M2X8 HEX CAP SCREW

**SP-OXY3-049 - OXY3 -
Main Frame, 2 PC**

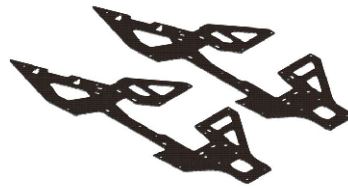

2 x MAIN FRAME

**SP-OXY3-051 - OXY3 -
Break Away Canopy Plate**



1 x OXY3 MOTOR MOUNT STIFFENER

**SP-OXY3-067 - OXY3 -
Main Shaft Bearing Block - Service Bag**



3 x Radial Bearing 4x10 W4

**SP-OXY3-152 -
Bottom plate, CF -TE**



1 x BOTTOM PLATE
4 x BOTTOM SCREW M2x3



<p>SP-OXY3-123 - OXY3 - Tail Rotor Assembly</p>  <ul style="list-style-type: none"> 1 x Tail Hub 2 x O-Ring ID2 W1 2 x 3x4x0.1 Shim 2 x Tail Grip 4 x 3x6x2 Radial Bearing 2 x 4.2x6x0.2 Shim 2 x 3x6x3.5 Thrust Bearing 2 x 3x4x0.1 Shim 2 x 4x3xM2 Ball 2 x 2X3.5X0.5 Washer 2 x M2x5 Hex Cap Screw 2 x M2x10 Bottom Screw 1 x M3x3 Set Screw 	<p>SP-OXY3-124 - OXY3 - Bell Crank Support</p>  <ul style="list-style-type: none"> 1 x Bell Crank Support 2 x 2X5X2.3 Flange Bearing 2 x M2X5 Bottom Screw 	<p>SP-OXY3-125 - OXY3 - Tail Pitch Slider</p>  <ul style="list-style-type: none"> 1 x Tail Pitch Slider Ring 2 x 4X7X2.5 Flange Bearing 1 x Tail Pitch Slider Half Moon 1 x Tail Pitch Slider Bushing 2 x 2X3X2 Bushing 2 x Link Control 1 x O-Ring ID 6 - W 2 2 x M2X5 Bottom Screw
<p>SP-OXY3-126 - OXY3 - Tail Case Bearing Block Assembly</p>  <ul style="list-style-type: none"> 1 x Tail Case Bearing Block 1 x 3X7X3 Flange Bearing 2 x M2X5 Hex Cap Screw 	<p>SP-OXY3-127 - OXY3 - Vertical Fin</p>  <ul style="list-style-type: none"> 1 x Vertical Fin 1 x Tail Case - Bearing Bushing 1 x 3X7X3 Radial Bearing 2 x M2X5 Hex Cap Screw 	<p>SP-OXY3-128 - OXY3 - Tail Bell Crank</p>  <ul style="list-style-type: none"> 1 x Tail Bell Crank 2 x Tail Pin Screw 2 x M2X5 Bottom Screw 1 x 4X2X4.2 M2 Linkage Ball
<p>SP-OXY3-129 - OXY3 - Tail Push Rod Set</p>  <ul style="list-style-type: none"> 1 x CF Rod 214mm 2 x Tail Push Rod Terminal 2 x Thread Rod M1.6X10 2 x 4mm Linkage Ball 2 x Pin Screw 1 x Guide Push Rod 	<p>SP-OXY3-130 - OXY3 - Tail Servo Mount, Set</p>  <ul style="list-style-type: none"> 2 x Tail Servo Mount 2 x M2x5 Hex Cap Screw 2 x M2x6 Hex Cap Screw 2 x Frame C Washer M2 	<p>SP-OXY3-107 - OXY3 - 285 Stretch - Tail Boom Spare</p>  <p>1xSquare Boom 11X14X320</p>

SP-OXY3-029 - OXY3 - Tail Shaft 14T



- 1 X Tail Shaft
- 1 X 14T Tail Pulley
- 2 X Flange Tail Pulley
- 4 X 3X4X0.1 Shim

SP-OXY3-080 - OXY3 - Tail Shaft 15T

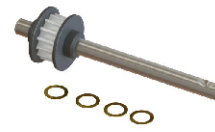

- 1 X Tail Shaft
- 1 X 15T Tail Pulley
- 2 X Flange Tail Pulley
- 4 X 3X4X0.1 Shim

SP-OXY3-025 - OXY3 - Tail Rotor - Service Bag



- 4X3XM2 Ball
- 4 x 3X6X2 Radial Bearing
- 2x 4.2X6X0.2 Shim
- 2 x 3X6X3.5 Thrust Bearing

SP-OXY3-028 - OXY3 - Tail Pitch Slider - Service Bag



- 2 x 2X3X2 Bushing
- 2 x Link Control
- 2 x M2X5 Button Screw

SP-OXY3-032 - OXY3 - Tail Case Cover



- 1 x Tail Case Cover
- 2 x M2X5 Hex Cap Screw

SP-OXY3-034 - OXY3 - Tensioner Tail Belt



- 1 x Bearing Bushing
- 2 x Radial Bearing 3X6X2.5
- 1 x M2X3 Button Screw
- 1 x M2X6 Button Screw

SP-OXY3-108 - OXY3 - 285 Stretch - Tail Belt Spare



- 1 x Tail Belt Stretch - B424MXL

SP-OXY3-048 - OXY3 - Tail Case Hub

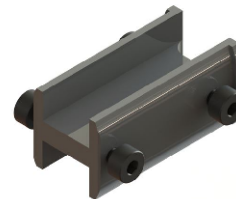

- 1 x Tail Case Center
- 2 x M2X5 Hex Cap Screw

SP-OXY3-059-2 - OXY3 - Tail Blade 50mm - Green



- 2 x Tail Blade 50mm-Green

SP-OXY3-058-1 - OXY3 - Tail Blade 47mm - Orange



- 2 x Tail Blade 47mm-Orange

SP-OXY3-058-2 -
OXY3 - Tail Blade 47mm - Green



SP-OXY3-059-1 -
OXY3 - Tail Blade 50mm - Orange



2 x Tail Blade 50mm-Orange

SP-OXY3-058-4 -
OXY3 - Tail Blade 47mm - Yellow



2 x Tail Blade 47mm-Yellow

SP-OXY3-058-3 -
OXY3 - Tail Blade 47mm - Black



2 x Tail Blade 47mm-Black

SP-OXY3-059-4 -
OXY3 - Tail Blade 50mm - Yellow



2 x Tail Blade 50mm-Yellow

SP-OXY3-059-3 - OXY3 -
Tail Blade 50mm - Black



2 x Tail Blade 50mm-Black

ACCESSORIES:

**SP-OXY3-065 -
Canopy Grommet, 4 PC**



4 x Canopy Gromet

**SP-OXY3-133-
C washer M2, Orange, 20pcs**



Frame C Washer M2 - Orange

**SP-OXY3-081 -
OXY3 - Vertical Fin Sticker Yellow**



Vertical Fin Sticker - Yellow

**SP-OXY3-082 -
OXY3 - Vertical Fin Sticker Orange**



Vertical Fin Sticker - Orange

**SP-OXY3-083 -
OXY3 - Vertical Fin Sticker White**



Vertical Fin Sticker - White

**SP-OXY3-084 -
OXY3 - Vertical Fin Sticker Green**



Vertical Fin Sticker - Green

**SP-OXY3-036 -
OXY3 - Servo Arm Set, 4 PC**



4 x Servo Arm
4 x 4X2X4.2 M2 Linkage Ball
4 x M2 Hex Nut

**SP-OXY3-039 -
OXY3 - Pinion 10T - Shaft 3.17**



1 x Pinion 10T- M0.5 - 3.17 Motor Shaft
1 x M3X3 Set Screw

**SP-OXY3-040 -
OXY3 - Pinion 11T - Shaft 3.17**



1 x Pinion 11T- M0.5 - 3.17 Motor Shaft
1 x M3X3 Set Screw

**SP-OXY3-041 -
OXY3 - Pinion 12T - Shaft 3.17**



1 x Pinion 12T- M0.5 - 3.17 Motor Shaft
1 x M3X3 Set Screw

SP-OXY3-042 -
OXY3 - Pinion 13T - Shaft 3.17



1 x Pinion 13t- M0.5 - 3.17 Motor Shaft
1 x M3X3 Set Screw

SP-OXY3-043 -
OXY3 - Pinion 14T - Shaft 3.17



1 x Pinion 14t- M0.5 - 3.17 Motor Shaft
1 x M3X3 Set Screw

SP-OXY3-044 -
OXY3 - Pinion 15T - Shaft 3.17



1 x Pinion 15t- M0.5 - 3.17 Motor Shaft
1 x M3X3 Set Screw

SP-OXY3-052 -
OXY3 - Swashplate Leveler Tool



1 x Leveler Tool

SP-OXY3-053 -
10mm Electronic Hook & Loop, 2 PC



2 x 10mm Electronic Hook&Loop

SP-OXY3-054 - OXY3 -
Battery Hook & Loop, 2 Set



Hook&Loop Set 1pc Male + 1pc Female

SP-OXY3-055 - OXY3 -
Double Side Adhesive Tape, 2PC



2 x Double Side Ahesive Tape 25mmX50mm

SP-OXY3-057 -
OXY3 - Cable Ties Set



15 x Cable Tie 3X100mm
5 x Cable Tie 3x60mm